

1-800-841-8188 • HEIDTS.COM

HEIDTS[®]

SUSPENSION SYSTEMS



1980 Pontiac Trans Am
Brad Riehoff
West Bend Dyno
1967 Chevy Nova
Amy Dayton
ARS Promotions
1970 Chevy Camaro
Randy Johnson
DSZ Customs
1968 Chevy Camaro
Heidts Hot Rod

Volume 27

**Leading Innovator
of Muscle Car and
Street Rod Suspensions**



INSIDE: STEP-BY-STEP INSTALL HEIDTS PRO-G[®] INDEPENDENT SUSPENSIONS

NEW: CHEVY C-10 AND FORD F-100 FRONT SUSPENSION / REAR 4-LINK

INDEX

Camaro: 1967-'81 & Nova: 1968-'79

- Coil-Overs 11
- Control Arms 11
- Disc Brakes 11
- Independent Rear HEIDTS Pro-G® IRS System 8, 9
- Pro-G Subframe 4, 33
- Rear 4-Link 5, 7, 34
- Spindles, Dropped 11
- Stabilizer Bar Kit 11
- Right Hand Suspension Systems 40

Camaro/Firebird: 1982-'92

- Subframe Connectors 10
- Rear Control Arms 10
- GM Bolt-On Torque Arm 10
- GM Pan Hard Bars 10

Chevy Chevelle & GM A-Body: 1964-'72

- Chassis Brace Links 13
- Coil-Overs 12
- Control Arms 11
- Disc Brakes 12
- Rear 4-Links 13
- Spindles, Dropped 12

Mustang: 1964½-'70, Cougar: 1967-'68, Falcon: 1963-'65

- Brake Pedals 15
- Chassis Stiffeners 17
- Front HEIDTS Pro-G® Full Front Suspension System 18
- HEIDTS Superide® 16
- Independent Rear HEIDTS Pro-G® IRS System 19
- Inner Fender Panels 15
- KENNY BROWN PERFORMANCE By HEIDTS® 20-25
- Motor Mounts 15
- Rear 4-Link Kit 17
- Steering Kits 15
- Subframe Connectors 17
- Suspension Packages 14, 15, 16
- Right Hand Suspension Systems 40

Mustang: 1979-2013 - KENNY BROWN by HEIDTS®

- 2-PT Heavy-Duty Strut Tower Brace 23
- 2-PT Lower Chassis Brace 23
- 3-PT Heavy-Duty Strut Tower Brace 23
- Adj. Heavy-Duty Front Sway Bar 24
- Adj. Rear Control Arms 20
- Adj. Rear Lower Control Arms 25
- Adj. Rear Upper Control Arms 25
- AGS 4.0 Light-Weight Tubular Front K-Member 20
- Anti-Squat Traction Brackets 20, 25
- Caster Plus Upper Strut Mount Kit 24
- Double-Cross Subframe Connectors 22
- Extreme Matrix Brace 22
- GT-4 "Super-Grip Front Lower Control Arm Module 20
- Heavy Duty Rear Adjustable Panhard Bar 21
- IRS Aluminum Differential Bushing Kit 25
- IRS Forward Torque Brace 25
- IRS Rear Lower Control Arms 25
- IRS Rear Steer Kit for 1999-2004 SVT Cobra 25
- IRS Rear Upper Control Arms 25
- Jacking Rails 22
- Light-Weight Tubular Front K-Member 24
- Rear Shock Tower Brace 23
- Roll Center Relocation Kit 21
- The Extreme Matrix Kit 22
- Tubular Front Lower Control Arms w/Low-Frict. Ball Joints 24
- U-Link Rear Upper Control Arm Module - Street/Comp 21

Fairlane & Comet: 1966-'67

- Rear 4-Link Kit 27
- HEIDTS Superide® II 26
- Right Hand Suspension Systems 40

Chevy Nova: 1962-'67

- Front HEIDTS Pro-G® Full Front Suspension System 30
- Front Subframe 28
- Independent Rear HEIDTS Pro-G® IRS System 32
- Inner Fender Panels 28
- Rear 4-Link Asmby. 31
- Stabilizer Bar Kit 28
- Subframe/Crossmember Asmby. 31
- HEIDTS Superide® II 29
- Right Hand Suspension Systems 40

Nova: 1968-'74

- Front HEIDTS Pro-G® Full Front Suspension System 33
- Rear 4-Link 34

Chevy: 1955-'57

- Coil-Overs 35
- Control Arms 35
- Disc Brakes 36
- HEIDTS PRO-G® IRS 36
- Rear 4-Link 37
- Spindles, Dropped 36
- Stabilizer Bar Kit 35

Classic Trucks

- Chevy: 1955-'59 44, 45, 56, 57
- Ford: 1953-'64 44, 45, 56, 57
- Right Hand Suspension Systems 41

Ford F-100: 1965-'72

- Heavy Duty Front Subframe Suspension System 58
- Heavy Duty Rear 4-Link 59

Chevy C-10: 1967-'72

- Heavy Duty Front Subframe Suspension System 60
- Heavy Duty Rear 4-Link 61

Mustang II

- Air Shock Suspension System 49
- Control Arms 48, 49
- IFS Kits-Chevy, Ford, Multi-Fit 44, 45, 46, 47
- Replacement/Rebuild Parts 72, 73
- Right Hand Suspension Systems 41
- Suspension Components 46, 48, 49
- Suspension Packages 47
- Tubular Strut Rods 47, 48

HEIDTS PRO-G® Universal IRS 39

SUPERIDE® IFS Systems

- Chevy: 1934-'35, most early systems 50, 51
- Ford: 1928-'34 50, 51
- Open Wheel (outboard & inboard shocks) 52, 53
- Right Hand Suspension Systems 41

HEIDTS SUPERIDE® II IFS Systems

- Chevy: 1937-'39, Ford: 1935-'48 54, 55
- Chevy Pick-Up, 1947-'59 54, 56, 57
- Ford Pick-Up, '35-'41, Willy's: '37-'41 54, 55
- Ford Pick-Up, '53-'56 56, 57
- Right Hand Suspension Systems 40

HEIDTS SUPERIDE® IRS Systems 42, 43

Street Rod & Classic Truck 4-Links 62, 63

Misc. Items

- Brake Calipers: Avail. Separately 67
- Brake Line Fittings 68
- Coil-Over Shocks 64, 64
- Column Hook-Up Kits 70, 71
- Disc Brakes & Brake Parts 66, 67
- Disc Brakes Conversion Kits 66, 67

- Headers 83
- Installation Information 74-80
- Motor Mounts 69
- Panhard Bars 63
- Power Steering Hose Kits 71
- Power Steering Proportioning Valve 68
- Proportioning Valves 68
- Questions/Answers 81
- Rear Disc Brake Kit 66
- Spring Spacers 72
- Stabilizer Bars 69
- Stainless Brake Lines 68
- Steering Columns 70
- Steering Components 70, 72
- Toe Plates 73
- Universal Brake Pedal Assembly 73
- Vette/Wilwood Conversion Kits 67
- Vibration Dampeners 70, 71

NEW

HEIDTS®

HEADERS

A TRUE FIT



**DESIGNED TO
FIT PERFECTLY
WITH HEIDTS
FRONT
SUSPENSIONS!**

PAGE - 83



HEIDTS® Has a New Home!





Heidts Automotive Group has moved to their new home in Lake Zurich, Illinois. The new building is over three times the size of the previous location and allows Heidts to increase efficiency, design and build new products more quickly and increase inventory for even faster product delivery.

The new building features the incorporation of our new shock line that completes the circle of performance suspension parts available from Heidts," stated Heidts Performance Group CEO Wallace Leyshon. "Key to the move is increasing the size of our R & D environment to help develop and deliver products for an ever widening breadth of product coverage by our Group companies."



HEIDTS® FRONT SUSPENSION SYSTEMS COMPARISON GUIDE

	GOOD	BETTER	BEST
	 PAGE 46	 PAGE 54	 HEIDTS PRO-G® PAGE 77
	Mustang II	HEIDTS SuperRide® II	HEIDTS PRO-G®
Upper Arm	T-Bolt Style	Heim-Style	Heim-Style
Springs/Shocks	Standard Spring and Shock	Adjustable Coil-Over Shocks	Adjustable Coil-Over Shocks
Crossmember	Single Crossmember	Single Crossmember	Double Crossmember
Brakes	GM Metric Caliper and Rotor	Wilwood Caliper and Granada Rotor	11" Full Wilwood Kit
Spindles	Mustang II Spindle Stock or Drop	Mustang II Spindle Stock or Drop	Heidts PRO-G® Spindle
Control Arm Thickness	7/8"	7/8"	1 1/4"
Geometry	Standard Geometry	Improved Geometry	Advanced Geometry

Order/Tech: 800-841-8188



'67-'69 CAMARO/FIREBIRD

HEIDTS PRO-G® FRONT SUBFRAME

LOWERS VEHICLE 2", 58 1/2" TRACK WIDTH

BOLT A "PRO-G™" ON YOUR CAR



HEIDTS® now offers their bolt on front subframe. Featuring their new Pro-G® suspension package for unbelievable cornering and overall handling. Simply unbolt and remove your front sheetmetal, engine/trans, old subframe, then slide in the new complete HEIDTS® Subframe. Reinstall your engine/trans and sheetmetal. HEIDTS® makes high end handling affordable!



*70-'81 CAMARO SHOWN.
Product is painted for catalog purposes only! All kits ship with Silver Powder Coated Springs - not shown.

*Shown with upgrades.
*Air bags will not fit.

PACKAGES SHIP UNASSEMBLED VIA TRUCK FRIEGHT.

INCLUDED IN BASE KIT:

- HEIDTS PRO-G® Subframe
- HEIDTS PRO-G® 2" Dropped Spindles
- Transmission X-Member
- Tubular Upper & Lower Arms
- Power Rack & Pinion Steering
- 11" Wilwood Brakes with Black Calipers
- Billet Coil-Over, Single Adjustable Shocks with Silver Powder Coated Springs

Now with Silver Powder Coated Springs! Powder coating does not rust or peel while saving you money!



CF-103

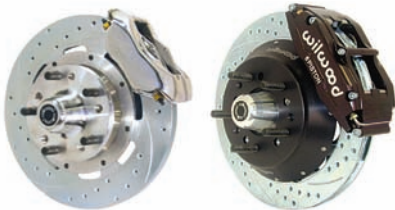

DF-222-D-P

DF-223-D-B

SP-110



MP-038-3-K



CB-160

TA-001

COMPLETE SUBFRAME BASE KIT

Description	Part#	Base Price
67-69 Camaro/Firebird (Includes Trans Crossmember)	CF-101-WT	5,092.00

CONTROL ARM OPTIONS

Description	Part#	Add
Plain Control Arms	CF-102	Included
Plain Control Arms 8" Addl. Positive Caster (optional)	CF-102-8-H	Included
Polished Stainless Steel Control Arms	CF-103	\$1879.00

BRAKE OPTIONS

Description	Part#	Add
11" Wilwood Smooth Rotors & 4 Piston Black Calipers	DF-221-B	Included
12" Wilwood Drilled Rotors & 4 Piston Black Calipers	DF-222-D-B	465.00
13" Wilwood Drilled Rotors & 6 Piston Black Calipers	DF-223-D-B	1685.00

Additional options available. Call for pricing.

SPINDLE OPTION

Description	Part#	Add
2" Dropped Spindles	SP-110	Included

POWER RACK & PINION OPTIONS

Description	Part#	Add
Power Rack	MP-038-3-K	Included
Power Rack W/ Stainless Steel Tie Rod Ends	MP-038-SS-K	135.00

SHOCK & SPRING OPTIONS

Description	Part#	Add
Plain Billet Coil-Over Shocks	CB-160	Included
400#, 450#, 500#, 550#, 600#, 700# Silver Powder Coated 10" Springs	CS-XXX-10	Included
Adjustable Spanner Wrench	TA-001	18.00
Thrust Bearings For Coil Over Shocks	CQ-010	40.00

ADDITIONAL OPTIONS

Description	Part#	Price
Upper Arm "Heim Style" Adjuster Kit	CF-104	213.00
67-69 Camaro/Firebird Pre Bent Brake Line Kit	CF-111	86.00
Steering Hookup Kit For Power Rack	SC-298	291.00
1" Swaybar	SB-110	281.00
1-1/4" Swaybar	SB-111	346.00
1-1/4" Splined Swaybar	SB-401	702.00
67-69 Camaro/Firebird Subframe Connectors, Coupe	CF-107-WT	224.00
67-69 Camaro/Firebird Subframe Connectors,Convertible	CF-110-WT	224.00
67-69 Camaro/Firebird Drive Shaft Hoop (Subframe Connectors Required)	RC-037	96.00
Body Mount Kit Urethane Bushings	CF-106	106.00
Body Mount Kit Aluminum Bushings	CF-109	244.00
Motor Mount Stands	MM-220	Included
LS Block Adapters Mounts (Urethane Mounts w/Adapters)(Short & Wide)	MM-200	163.00
Rubber Motor Mounts for Small Block Chevy	MM-120	64.00
Low Friction Upper Ball Joint	CC-070	65.00 ea.
Low Friction Lower Ball Joint	CC-071	65.00 ea.

'67-'69 CAMARO/FIREBIRD

HEIDTS PRO G REAR 4-LINK



LOWERS VEHICLE 2"

Bolt-on maximum performance for your Camaro or Firebird. Kit includes chassis and axle brackets, adjustable links, full upper coil-over crossmember, panhard bar, adjustable HEIDTS® coil-overs and all hardware. Completely bolt-on, with no cutting or floor modifications. Adjustable 4-link mounts allow suspension tuning.

COMPLETE 4-LINK BASE KIT

Description	Part#	Base Price
67-69 Camaro/Firebird	RC-101-WT	\$1507.00
67-69 Camaro/Firebird (Use If Ordering 9" Housing)	RC-101-WT-H	\$1507.00

LINKS & PANHARD BAR OPTIONS

Description	Part#	Add
Plain Links and Panhard Bar	RC-106	Included
Polished Stainless Steel Links and Panhard Bar	RC-107	\$747.00

SHOCK & SPRING OPTIONS

Description	Part#	Add
Black Coil-Over Shocks	CO-101	Included
250#, 300#, 350# Black Coil Springs	CR-XXX-11-B	Included
Billet Coil-Over Shocks/Silver Powder Coated Springs	CB-105	173.00
250#, 300#, 350# Silver Powder Coated Coil Springs	CR-XXX-11-C	Included
Adjustable Spanner Wrench	TA-001	18.00
Thrust Bearings For Coil Over Shocks	CQ-010	40.00

AXLE HOUSING AND AXLE OPTIONS

Description	Part#	Price
56" Track Width Housing With Brackets Installed	RC-040-56-H-WT	809.00
58" Track Width Housing With Brackets Installed	RC-040-58-H-WT	809.00
60" Track Width Housing With Brackets Installed	RC-040-60-H-WT	809.00
56" Track Width 31 Spline Axles with Chevy Bolt Pattern	RC-041-56-31	653.00
58" Track Width 31 Spline Axles with Chevy Bolt Pattern	RC-041-58-31	653.00
60" Track Width 31 Spline Axles with Chevy Bolt Pattern	RC-041-60-31	653.00

3RD MEMBER OPTIONS

Description	Part#	Add
Positraction 31 Spline 3, 3.25, 3.50, 3.70, 3.90, 4.11 Ratio	BN-XXX-I-L	1296.00

BRAKE OPTIONS

Description	Part#	Price
11" Heavy Duty Drum Brake	RN-054	630.00
12" Iron Rotors, GM Single Piston Calipers W/Parking Brake	DR-005-E-P	753.00
12" Wilwood Smooth Rotors & 4 Piston Black Calipers W/Parking Brake	DR-005-P-B	766.00
12" Wilwood Smooth Rotors & 4 Piston Red Calipers W/Parking Brake	DR-005-P-RED	861.00
12" Wilwood Smooth Rotors & 4 Piston Polished Calipers W/Parking Brake	DR-005-P	842.00
12" Wilwood Drilled Rotors & 4 Piston Black Calipers W/Parking Brake	DR-005-P-D-B	845.00
12" Wilwood Drilled Rotors & 4 Piston Red Calipers W/Parking Brake	DR-005-P-D-RED	945.00
12" Wilwood Drilled Rotors & 4 Piston Polished Calipers W/Parking Brake	DR-005-P-D	958.00

SUBFRAME CONNECTOR OPTIONS

Description	Part#	Price
67-69 Camaro/Firebird Subframe Connectors- Coupe	CF-107-WT	215.00
67-69 Camaro/Firebird Subframe Connectors- Convertible	CF-110-WT	226.00
67-69 Camaro/Firebird Subframe Connectors - Coupe (Factory Subframe)	RC-102	215.00
67-69 Camaro/Firebird Subframe Connectors - Convertible (Factory Subframe)	RC-103	215.00

ADDITIONAL OPTIONS

Description	Part#	Add
67-69 Camaro/Firebird Drive Shaft Hoop (Subframe Connectors Req.)	RC-037	96.00
67-69 Camaro/Firebird Rear Swaybar	SB-009	286.00

BOLT-IN REAR 4-LINK KIT

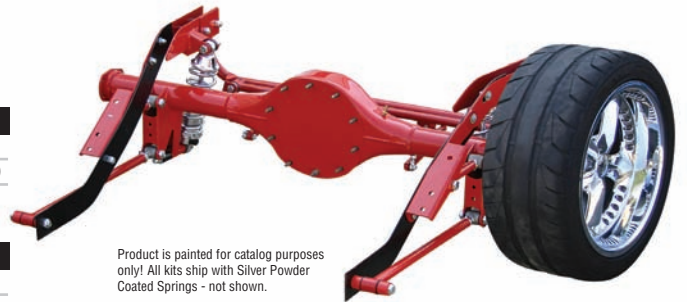

Product is painted for catalog purposes only! All kits ship with Silver Powder Coated Springs - not shown.



PACKAGES SHIP UNASSEMBLED VIA TRUCK FREIGHT.

INCLUDED IN BASE KIT:

- 4-Links with Spherical Bearings and Axle Brackets
- Top Crossmember
- Panhard Bar
- Standard Coil-Over Shocks, Black Body and Black Springs

Now with Silver Powder Coated Springs! Powder coating does not rust or peel while saving you money!



Order/Tech: 800-841-8188

HEIDTS
SUSPENSION SYSTEMS

HEIDTS® MUSCLE CAR PARTS

'70-'81 CAMARO/FIREBIRD,

HEIDTS PRO-G® FRONT SUBFRAME

LOWERS VEHICLE 2", 58 1/2" TRACK WIDTH



BOLT A "PRO-G" ON YOUR CAR



*70-'81 CAMARO SHOWN. Product is painted for catalog purposes only! All kits ship with Silver Powder Coated Springs - not shown.

*Shown with upgrades.
*Air bags will not fit.

PACKAGES SHIP UNASSEMBLED VIA TRUCK FRIEGHT.

INCLUDED IN BASE KIT:

- HEIDTS PRO-G® Subframe
- HEIDTS PRO-G® 2" Dropped Spindles
- Transmission X-Member
- Tubular Upper & Lower Arms
- Power Rack & Pinion Steering
- 11" Wilwood Brakes with Black Calipers
- Billet Coil-Over, Single Adjustable Shocks with Silver Powder Coated Springs

Now with Silver Powder Coated Springs! Powder coating does not rust or peel while saving you money!



CF-103



DF-222-D-P



DF-223-D-B



SP-110



MP-038-3-K



TA-001

CB-160

HEIDTS® now offers their bolt on front subframe. Featuring their new Pro-G® suspension package for unbelievable cornering and overall handling. Simply unbolt and remove your front sheetmetal, engine/trans, old subframe, then slide in the new complete HEIDTS® Subframe. Reinstall your engine/trans and sheetmetal. HEIDTS® makes high end handling affordable!

COMPLETE SUBFRAME BASE KIT

Description	Part#	Base Price
70-81 Camaro/Firebird (Includes Trans Crossmember)	CF-201-WT	5092.00

CONTROL ARM OPTIONS

Description	Part#	Add
Plain Control Arms	CF-102	Included
Plain Control Arms 8" Addl. Positive Caster (optional)	CF-102-8-H	Included
Polished Stainless Steel Control Arms	CF-103	\$1879.00

BRAKE OPTIONS

Description	Part#	Add
11" Wilwood Smooth Rotors & 4 Piston Black Calipers	DF-221-B	Included
12" Wilwood Drilled Rotors & 4 Piston Black Calipers	DF-222-D-B	465.00
13" Wilwood Drilled Rotors & 6 Piston Black Calipers	DF-223-D-B	1,685.00

Additional options available. Call for pricing.

SPINDLE OPTION

Description	Part#	Add
2" Dropped Spindles	SP-110	Included

POWER RACK & PINION OPTIONS

Description	Part#	Add
Power Rack	MP-038-3-K	Included
Power Rack W/ Stainless Steel Tie Rod Ends	MP-038-SS-K	135.00

SHOCK & SPRING OPTIONS

Description	Part#	Add
Plain Billet Coil-Over Shocks	CB-160	Included
400#, 450#, 500#, 550#, 600#, 700# Silver Powder Coated 10" Springs	CS-XXX-10	Included
Adjustable Spanner Wrench	TA-001	18.00
Thrust Bearings For Coil Over Shocks	CQ-010	40.00

ADDITIONAL OPTIONS

Description	Part#	Price
Upper Arm "Heim Style" Adjuster Kit	CF-104	213.00
Camaro/Firebird Pre Bent Brake Line Kit - PRO-G	CF-111	86.00
Steering Hookup Kit For Power Rack	SC-298	291.00
1" Swaybar	SB-110	281.00
1-1/4" Swaybar	SB-111	346.00
1-1/4" Splined Swaybar	SB-401	702.00
70-81 Camaro/Firebird Subframe Connectors	CF-202-WT	215.00
70-81 Camaro/Firebird Drive Shaft Hoop (Subframe Connectors Required)	RC-125	107.00
Body Mount Kit Urethane Bushings	CF-106	106.00
Body Mount Kit Aluminum Bushings	CF-109	244.00
Motor Mount Stands	MM-221	Included
Low Friction Upper Ball Joint	CC-070	65.00 ea.
Low Friction Lower Ball Joint	CC-071	65.00 ea.

'70-'81 CAMARO/FIREBIRD

HEIDTS PRO-G REAR 4-LINK

LOWERS VEHICLE 2"

Bolt-on maximum performance for your Camaro/Firebird. Kit includes chassis and axle brackets, adjustable links, full upper coil-over crossmember, panhard bar, adjustable HEIDTS® coil-overs and all hardware. Completely bolt-on, with no cutting or floor modifications. Adjustable 4-link mounts allow suspension tuning.



BOLT-IN REAR 4-LINK KIT

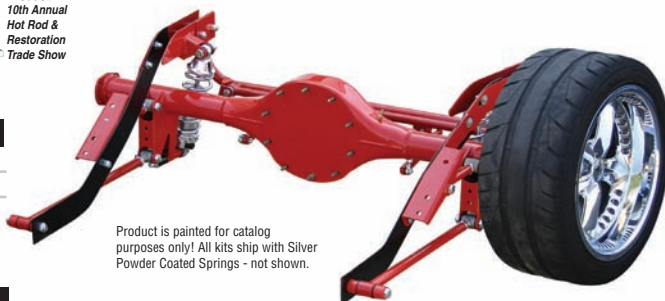

Product is painted for catalog purposes only! All kits ship with Silver Powder Coated Springs - not shown.

INCLUDED IN BASE KIT:

- 4-Links with Spherical Bearings and Axle Brackets
- Top Crossmember
- Panhard Bar
- Standard Coil-Over Shocks, Black Body with Black Springs



Now with Silver Powder Coated Springs! Powder coating does not rust or peel while saving you money!

COMPLETE BASE KIT

Description	Part#	Base Price
70-81 Camaro/Firebird	RC-121	1507.00
70-81 Camaro/Firebird (Use if ordering Heidts 9" housing)	RC-121-H	1507.00

LINKS & PANHARD BAR OPTIONS

Description	Part#	Add
Plain 4 Links and Bar Kit	RC-123	Included
Polished Stainless Steel 4 Links and Bar Kit	RC-124	747.00

SHOCK & SPRING OPTIONS

Description	Part#	Add
Black Coil-Over Shocks	CO-101	Included
250#, 300#, 350# Black Coil Springs	CR-XXX-11-B	Included
Billet Coil-Over Shocks/Silver Powder Coated Springs	CB-105	173.00
250#, 300#, 350# Silver Powder Coated Coil Springs	CR-XXX-11-C	Included
Adjustable Spanner Wrench	TA-001	18.00
Thrust Bearings For Coil Over Shocks	CQ-010	40.00

AXLE HOUSING AND AXLE OPTIONS

Description	Part#	Price
60" Track Width Housing With Brackets Installed	RC-130-60-H	809.00
60" Track Width 31 Spline Axles with Chevy Bolt Pattern	RC-041-60-31	653.00

3RD MEMBER OPTIONS

Description	Part#	Add
Positraction 31 Spline 3, 3.25, 3.50, 3.70, 3.90, 4.11 Ratio	BN-XXX-I-L	1296.00

BRAKE OPTIONS

Description	Part#	Price
11" Heavy Duty Drum Brake	RN-054	630.00
12" Iron Rotors, GM Single Piston Calipers W/Parking Brake	DR-005-E-P	753.00
12" Wilwood Smooth Rotors & 4 Piston Black Calipers W/Parking Brake	DR-005-P-B	766.00
12" Wilwood Smooth Rotors & 4 Piston Red Calipers W/Parking Brake	DR-005-P-RED	861.00
12" Wilwood Smooth Rotors & 4 Piston Polished Calipers W/Parking Brake	DR-005-P	842.00
12" Wilwood Drilled Rotors & 4 Piston Black Calipers W/Parking Brake	DR-005-P-D-B	845.00
12" Wilwood Drilled Rotors & 4 Piston Red Calipers W/Parking Brake	DR-005-P-D-RED	945.00
12" Wilwood Drilled Rotors & 4 Piston Polished Calipers W/Parking Brake	DR-005-P-D	958.00

SUBFRAME CONNECTOR OPTIONS

Description	Part#	Price
70-81 Camaro/Firebird Subframe Connectors (Factory)	RC-122	215.00
70-81 Camaro/Firebird Subframe Connectors (PRO-G)	CF-202-WT	215.00

ADDITIONAL OPTIONS

Description	Part#	Price
70-81 Camaro/Firebird Rear Swaybar	SB-170	193.00
70-81 Camaro/Firebird Drive Shaft Hoop (Subframe Connectors Req.)	RC-125	107.00
70-81 Camaro/Firebird Subframe Connectors-Coupe (PRO-G)	CF-202-WT	215.00
70-81 Camaro/70-81 Firebird Subframe Connectors (Factory)	RC-122	215.00



Order/Tech: 800-841-8188



HEIDTS® MUSCLE CAR PARTS

'67-'69, '70-'73 CAMARO/FIREBIRD



HEIDTS PRO-G® IRS

Now with Silver Powder Coated Springs! Powder coating does not rust or peel while saving you money!

HIGH HORSEPOWER INDEPENDENT REAR SUSPENSION 58 1/2" TRACK WIDTH

Product is painted for catalog purposes only! All kits ship with Silver Powder Coated Springs - not shown.



Available with cast aluminum center section or steel fabricated housing.

U.S. Patent No. D666,949 Additional Patents Pending



COMPLETE BASE KIT STARTING AT \$9,320

WHY HEIDTS PRO-G® IRS

Do you really want to go fast and out-handle everyone else on the autocross or road race course in your first generation camaro? Full independent rear suspension is the only way to go. **HEIDTS®** now has a High Horsepower Independent Rear Suspension bolt-In Package that will do the job just fine.

It is a true high horsepower package, with upper links and heavy duty CV joints. The upper link produces $-.5^\circ$ of camber curve at 3/4 of total travel, especially during very high cornering loads. Forward struts, attached to the sub-frame connectors insures the wheels stay in place during hard acceleration.

“About once every ten years, someone comes up with a breakthrough part in the aftermarket. The HEIDTS® Bolt-in Independent Rear suspension could be that part for 2011 and beyond”

Quoted from Jim Campisano – Editor
Super Chevy Magazine, January Issue

WHAT YOU GET:

- Track Width 58 1/2"
- 9" Aluminum HSG.
- 3rd Member, Iron, Posi
- CV Joint Halfshafts
- Tubular Upper & Lower Arms
- Steel Outer Uprights
- Top Crossmember
- Frame Mounting Brackets
- Front Pinion Support
- Forward Struts*
- 10.5" Wilwood Rotors
- Black Wilwood Calipers
- Billet Single Adjustable Coil-Overs with Silver Powder Coated Springs
- Posi-Traction

OPTIONS: CALL FOR DETAILS.

- Choice of Gear Ratios
- Parking Brake Kit and Cable Kit

'67-'69, '70-'73 CAMARO/FIREBIRD



HEIDTS PRO G IRS

HIGH HORSEPOWER INDEPENDENT REAR SUSPENSION

COMPLETE BASE KIT

Description	Part#	Base Price
67-69 Camaro/Firebird High Horsepower IRS - Plain Rotors	IRC-101	9320.00
67-69 Camaro/Firebird High Horsepower IRS - Drilled & Slotted Rotors	IRC-101-S	9654.00
70-73 Camaro/Firebird High Horsepower IRS - Plain Rotors	IRC-201	9320.00
70-73 Camaro/Firebird High Horsepower IRS - Drilled & Slotted Rotors	IRC-201-S	9654.00

SHOCK & SPRING OPTIONS

Description	Part#	Price
Plain Billet Coil-Over Shocks	CB-106	Included
350# Silver Powder Coated Springs	CS-350-10	Included
400# Silver Powder Coated Springs	CS-400-10	Included
450# Silver Powder Coated Springs	CS-450-10	Included
550# Silver Powder Coated Springs	CS-550-10	Included

3RD MEMBER OPTIONS

Description	Part#	Price
Positraction 31 Spline 3.00 Ratio	BN-300-I-L	Included
Positraction 31 Spline 3.25 Ratio	BN-325-I-L	Included
Positraction 31 Spline 3.50 Ratio	BN-350-I-L	Included
Positraction 31 Spline 3.70 Ratio	BN-370-I-L	Included
Positraction 31 Spline 3.90 Ratio	BN-390-I-L	Included
Positraction 31 Spline 4.11 Ratio	BN-411-I-L	Included

SUBFRAME CONNECTORS FOR PRO-G SUBFRAME

Description	Part#	Price
67-69 Camaro/Firebird Subframe Connectors - Coupe	CF-107-WT-RC	Included
67-69 Camaro/Firebird Subframe Connectors - Convertible	CF-110-WT-IRC	Included
70-73 Camaro/Firebird Subframe Connectors - Coupe	CF-202-WT-RC	Included

SUBFRAME CONNECTORS FOR FACTORY SUBFRAME

Description	Part#	Price
67-69 Camaro/Firebird Subframe Connectors - Coupe	RC-102-IRC	Included
67-69 Camaro/Firebird Subframe Connectors - Convertible	RC-103-IRC	Included
70-73 Camaro/Firebird Subframe Connectors	RC-122-IRC	Included

PARKING BRAKE OPTIONS

Description	Part#	Price
Parking Brake Kit & Cable Kit	PB-101	589.00
E-Stop Actuator	BM-013	699.00

HOUSING OPTIONS

Description	Part#	Add
Polished Aluminum 9" Housing	BM-001-P	205.00
Steel Fab 9" Housing	BT-410	



Product is painted for catalog purposes only! All kits ship with Silver Powder Coated Springs - not shown.

***Subframe Connectors Included.**



PB-101



Order/Tech: 800-841-8188

HEIDTS[®] MUSCLE CAR PARTS



'82-'92 CAMARO/FIREBIRD

BOLT-ON SUBFRAME CONNECTOR

No cutting or welding to install allowing you to retain your stock exhaust, fuel and brake lines. These connectors come complete with grade 8 hardware and instructions. They are powder coated black to insure long life and beauty. (they can also be welded)

Description	Part#	Price
82-92 Camaro/FireBird	102411	261.00

BOLT-ON REAR CONTROL ARMS

Genuine Energy Suspension bushings are used exclusively for a long life with low maintenance. Profile milled sway bar mounts. Powder coated gloss black for a long lasting beautiful finish.

Description	Part#	Price
82-92 Camaro/FireBird, F-Body	401010	195.00

GM BOLT ON TORQUE ARM

Our BOLT ON TORQUE ARM features an 1/8" steel plate cradle that replaces the factory rubber mount. Our Torque Arm not only improves traction but significantly increases stability under deceleration. Our adjustable Torque Arm enables you to adjust the pinion angle. *These only fit OEM rear end housings.

Description	Part#	Price
(Adjustable) 82-92 Camaro/FireBird	402013	472.00
(Adjustable) 93-02 Camaro/FireBird	402015	472.00
(Standard) 82-92 Camaro/FireBird	402018	367.00
(Standard) 93-02 Camaro/Firebird	402019	367.00

GM PAN HARD BARS

ALSTON tubular design PAN HARD BARS replaces the factory u-channel style, providing more chassis stability. Energy Suspension bushings dramatically resist deflection keeping the housing centered and improving cornering ability

Description	Part#	Price
82-02 Camaro/Firebird	401061	132.00



102411



401010



402013



401061

ALSTON PERFORMANCE SUSPENSION KITS

'64-'72 A-BODY KIT

KIT INCLUDES:

- TUBULAR FRONT UPPER CONTROL ARMS
- TUBULAR FRONT LOWER CONTROL ARMS
- ADJUSTABLE COIL OVER SHOCKS AND SPRINGS
- BOLT ON TUBULAR REAR UPPER CONTROL ARMS*
- BOLT ON TUBULAR REAR LOWER CONTROL ARMS
- SWAY BAR MOUNTS
- REAR CONTROL ARM SUPPORT TUBES

*OPTION: REAR UPPER ADJUSTABLE CONTROL ARM

'70-'81 CAMARO KIT

KIT INCLUDES:

- TUBULAR FRONT UPPER CONTROL ARMS
- TUBULAR FRONT LOWER CONTROL ARMS
- ADJUSTABLE COIL OVER SHOCKS AND SPRINGS
- SUB FRAME CONNECTOR
- FIREWALL Y-BRACE

'67-'69 CAMARO KIT

KIT INCLUDES:

- BOLT ON SUBFRAME CONNECTOR
- TUBULAR FRONT UPPER CONTROL ARMS
- TUBULAR FRONT LOWER CONTROL ARMS
- ADJUSTABLE COIL OVER SHOCKS AND SPRINGS

'82-'02 CAMARO KIT

KIT INCLUDES:

- BOLT ON TUBULAR REAR LOWER CONTROL ARMS
- BOLT ON SUB FRAME CONNECTOR
- PANHARD BAR
- BOLT ON TORQUE BAR

*OPTION: REAR UPPER ADJUSTABLE CONTROL ARM



UPPER AND LOWER CONTROL ARMS

Description	Part#	Price
67-69 Camaro/Firebird/68-74 Nova Upper Control Arms	CA-301	465.00
70-81 Camaro Upper Control Arms	CA-302	479.00
67-69 Camaro /Firebird/68-74 Nova Lower Control Arms	CA-311	725.00
67-69 Camaro/Firebird/68-74 Nova Coil-Over Lower Control Arms	CA-311-M	725.00
70-81 Camaro/Firebird Lower Control Arms	CA-312	780.00
70-81 Camaro/Firebird Coil-Over Lower Control Arms	CA-312-M	780.00
Narrowed Tie Rod Ends for Narrowed Control Arms***	CC-064	22.00 ea.



CA-302

CA-312-M

WILWOOD™ DISC BRAKES

Description	Part#	Price
11" Wilwood Smooth Rotors & 4 Piston Black Calipers	DF-221-B	811.00
11" Wilwood Drilled Rotors & 4 Piston Red Calipers	DF-221-D-RED	1024.00
11" Wilwood Drilled Rotors & 4 Piston Polished Calipers	DF-221-D-P	1024.00
12" Wilwood Drilled Rotors & 4 Piston Black Calipers	DF-222-D-B	1,014.00
12" Wilwood Drilled Rotors & 4 Piston Red Calipers	DF-222-D-RED	1,080.00
12" Wilwood Drilled Rotors & 4 Piston Polished Calipers	DF-222-D-P	1,083.00
13" Wilwood Drilled Rotors & 6 Piston Black Calipers	DF-223-D-B	1,952.00
13" Wilwood Drilled Rotors & 6 Piston Red Calipers	DF-223-D-RED	1,945.00
13" Wilwood Drilled Rotors & 6 Piston Polished Calipers	DF-223-D-P	2,153.00

For 67-69 Camaro/Firebird & 68-74 Nova only!



DF-221-B

DF-222-D-B

COIL OVER SHOCKS

Description	Part#	Price
67-69 Camaro/Firebird/68-74 Nova Coil-Over Shocks	CB-130	400.00
70-81 Camaro/Firebird Coil-Over Shocks	CB-120	400.00
67-69 Camaro 450# SBC	CQ-450-11	162.00
70-81 Camaro 450# SBC	CQ-450-10-F	162.00
67-69 Camaro/Firebird/68-74 Nova 550# 11" Silver Powder Coat Springs - Big Block	CQ-550-11	162.00
70-81 Camaro/Firebird 550# 10" Silver Powder Coat Springs - Big Block	CQ-550-10-F	162.00
Thrust Bearings For Coil-Over Shocks	CQ-010	40.00
Spanner Wrench	TA-001	18.00

Available for Small and Big Block



CB-130

HIGH PERFORMANCE TALL 2" DROPPED STEEL SPINDLE

It is called a TALL Spindle because the upper ball joint is raised 1-1/2". Different from the factory design, it yields a better camber change during suspension movement. Pivot points are determined by the ball joints on the spindles and bushing locations on the frame, not the control arms. These spindles are STEEL, the strongest ones in the industry.



Description	Part#	Price
2" Dropped Spindles, Pair	SP-110	341.00

For 67-69 Camaro/Firebird & 68-74 Nova only!



SP-110

SB-069

SWAYBARS

Description	Part#	Price
67-69 Camaro/Firebird/68-72 Nova 1-1/8" Diameter Swaybar	SB-069	238.00
70-81 Camaro/Firebird 1-5/16" Diameter Swaybar	SB-070	308.00

For 67-69 Camaro/Firebird & 68-74 Nova only!



'64-'72 CHEVELLE & GM A-BODY PRE '73

GM A-BODY CONTROL ARMS

Replace your tired control arms with **HEIDTS®** tubular upper and lower control arms for the '64-'72 Chevelle, GTO and all other GM A-body cars. These arms are state of the art in both design and fabrication. Uppers are 1-1/4" dia. tube, and the lowers are a full 1-1/2" tube. They all come powder coated and are supplied with ball joints and bushings installed. High performance urethane bushings are standard to tighten up the suspension and allow no deflection under cornering loads for absolutely solid, positive handling. Upper arms include offset cross shafts for ease of alignment and allow you to experiment with caster settings, allowing better straight line tracking as well as in the corners. All arms are completely assembled.

CA-401



CA-411



Description	Part#	Price
64-72 Chevelle/GM A-Body Upper Control Arms	CA-401	465.00
64-72 Chevelle/GM A-Body Lower Control Arms	CA-411	654.00
64-72 Chevelle/GM A-Body Coil-Over Lower Control Arms	CA-411-M	626.00

****We Recommend Using Our Pro-G Dropped Spindles (SP-110) With Our Control Arms Control Arms can be shipped unassembled for powdercoat painting.**

WILWOOD™ DISC BRAKES

Description	Part#	Price
11" Wilwood Smooth Rotors & 4 Piston Black Calipers	DF-221-B	811.00
11" Wilwood Drilled Rotors & 4 Piston Red Calipers	DF-221-D-RED	1,024.00
11" Wilwood Drilled Rotors & 4 Piston Polished Calipers	DF-221-D-P	1,024.00
12" Wilwood Drilled Rotors & 4 Piston Black Calipers	DF-222-D-B	1,014.00
12" Wilwood Drilled Rotors & 4 Piston Red Calipers	DF-222-D-RED	1,080.00
12" Wilwood Drilled Rotors & 4 Piston Polished Calipers	DF-222-D-P	1,083.00
13" Wilwood Drilled Rotors & 6 Piston Black Calipers	DF-223-D-B	1,952.00
13" Wilwood Drilled Rotors & 6 Piston Red Calipers	DF-223-D-RED	1,945.00
13" Wilwood Drilled Rotors & 6 Piston Polished Calipers	DF-223-D-P	2,153.00

For 67-69 Camaro/Firebird & 68-72 Nova only!



DF-221-B



DF-222-D-B

CHEVELLE & GM A-BODY COIL OVER SHOCKS

Coil-Over Shocks make the suspension more tunable, and **HEIDTS®** has them. Billet shock bodies with powder coated springs in different spring rates are the ticket. These shocks are fully adjustable with just the turn of a knob in both compression and rebound for full performance tuning. Ride height is also tunable with adjustment rings. Springs included.



CB-130

Description	Part#	Price
64-72 Chevelle & GM A-Body Coil-Over Shocks	CB-130	400.00
64-72 Chevelle & GM A-Body 450# 11" Silver Powder Coat Springs (SBC)	CQ-450-11	162.00
64-72 Chevelle & GM A-Body 550# 11" Silver Powder Coat Springs (BBC)	CQ-550-11	162.00
64-72 Chevelle & GM A-Body 650# 11" Silver Powder Coat Springs (BBC)	CQ-650-11	162.00
Thrust Bearings For Coil-Over Shocks	CQ-010	40.00
Spanner Wrench	TA-001	18.00



SP-110

HIGH PERFORMANCE TALL 2" DROPPED STEEL SPINDLE

It is called a TALL Spindle because the upper ball joint is raised 1-1/2". Different from the factory design, it yields a better camber change during suspension movement. Pivot points are determined by the ball joints on the spindles and bushing locations on the frame, not the control arms. These spindles are STEEL, the strongest ones in the industry.



Description	Part#	Price
2" Dropped Spindles, Pair*	SP-110	341.00

***Must use HEIDTS® Control Arms**

'64-'72 CHEVELLE & GM A-BODY PRE '73



REAR 4-LINK PACKAGES

At HEIDTS® the answer to handling is their upper and lower rear Suspension Links for the '64-'72 Chevelle, GTO and all other GM A-body cars. These links are state of the art in both design and fabrication. Upper Links are adjustable, 1-1/4" dia. tube, and the lowers area full 1-1/2" x 2" square tube. They come powder coated black and are supplied with greaseable swivel and fixed bushings installed. High performance urethane bushings are used to tighten up the suspension and swivel ends allow roll deflection under cornering loads for absolutely solid, positive handling. All rear links are completely assembled, ready to install and include new hardware.

Description	Part#	Price
64-66 Chevelle / 64-66 GM A-Body Rear 4-Link	RC-240	863.00
67-72 Chevelle / 67-72 GM A-Body Rear 4-Link	RC-250	863.00

CHASSIS BRACE LINKS

Chassis Brace Links attach to the upper bolt of the Rear 4-Links and to the chassis crossmember. They take the added stress from the new Rear 4-Links. Sold in pairs.

Description	Part#	Price
64-66 Chevelle/GM A-Body Rear Axle Link Braces	RC-255	157.00
67-72 Chevelle/GM A-Body Rear Axle Link Braces	RC-251	157.00

SWAYBARS

Description	Part#	Price
64-72 1 1/8" Chevelle Front Swaybar	SB-071	227.00
64-72 1" Chevelle Rear Swaybar**	SB-150	222.00

**Must Use HEIDTS® 4-Link Package



RC-250



RC-255



SB-071

JOIN THE FUN!

IT'S THE NEED FOR SPEED

For 2015 dates & exciting photos of the 2014 event
go to <http://www.heidts.com/hpcc-2014-results/>

**'64½ - '70 MUSTANG, '67-'70 COUGAR
'60-'65 FALCON, '64-'65 COMET**

MUSTANG II IFS

Owner & Builder:
Stang-Aholics



Now you can give your Mustang superior handling. **HEIDTS®** now offers Mustang II Front Suspension crossmembers and components to make it easy!



**COMPLETE BASE KIT
STARTING AT \$2,425**

Shown with options.
Product is painted for catalog purposes only!

COMPLETE BASE KIT

Description	Part#	Base Price
64 1/2 -70 Mustang/67-70 Cougar	PX-320-E-K	2,425.00
60-65 Falcon /64-65 Comet	PX-330-E-K	2,425.00

CONTROL ARM OPTIONS

Description	Part#	Add
Tubular Arms (Narrowed available)	CA-112	Included
Stainless Steel Tubular Arms (Narrowed available)	CA-112-SS	1,188.00

BRAKE OPTIONS

Description	Part#	Add
11" Iron Rotors & GM Calipers	DF-201-B-G or F-G	Included
12" Wilwood Drilled Rotors & 4 Piston Polished Calipers	DF-208-P-K	1,127.00
13" Wilwood Drilled Rotors & 6 Piston Polished Calipers	DF-206-P-K	1,896.00

Additional options available. Call for pricing.

SPINDLE OPTIONS

Description	Part#	Add
2" Dropped Spindles	SP-101-K	Included

RACK & PINION OPTIONS

Description	Part#	Add
Manual Rack & Pinion	MP-018-K	Included
Power Rack & Pinion	MP-038-3-K	140.00
Power Rack W/ Stainless Steel Tie Rod Ends	MP-038-SS-K	275.00

SHOCK & SPRING OPTIONS

Description	Part#	Add
Stock Springs & Shocks 275# - 375#	MP-007-XXX-K	Included
Billet Coil-Over Shocks & Springs 350# - 700#	MP-050-XXX-K	486.00
Thrust Bearings For Coil-Over Shocks	CQ-010	40.00
Spanner Wrench	TA-001	18.00

HEIDTS® suspension systems will give your Mustang, Cougar or Falcon the ride, handling and stopping power you are after (Comes standard with dropped spindles). Assembled package is shown so you can see what your completed front end will look like.

INCLUDED IN BASE KIT:

- **HEIDTS®** Crossmember • 2" Dropped Spindles • Tubular Upper & Lower Arms • 11" Rotors with Single Piston Calipers
- Manual Rack & Pinion Steering • Stock Shocks & Springs

* Air bags will not fit.

***Note:** These kits all require the use of a Rear Sump Style Oil Pan, and some Ford engines may require the use of a High-rise Hood to clear the intake system! Also, Ford 351 Cleavelands will fit using dry sump with our kits!



MP-038-3-K



SP-101-K

DF-201

DF-208

DF-206

**'64½ - '70 MUSTANG, '67-'70 COUGAR
'60-'65 FALCON, '64-'65 COMET**



MUSTANG II IFS

Now you can give your Mustang superior handling. **HEIDTS®** now offers Mustang II Front Suspension crossmembers and components to make it easy!

Now with Silver Powder Coated Springs! Powder coating does not rust or peel while saving you money!

ADDITIONAL OPTIONS

Description	Part#	Price
Swaybar	SB-065	286.00
Polished Stainless Steel Balljoint Caps, Pair	MP-034	66.00
64-66 Mustang Inner Panels	PX-325	70.00
67-70 Mustang Inner Panels	PX-326	70.00
64-66 Mustang 36 Spline Power Rack Steering Kit For Stock Column DD Shaft	SC-290-DD	373.00
64-66 Mustang Manual Rack Steering Kit For Stock Column DD Shaft	SC-291-DD	373.00
67-68 Mustang Power Rack Steering Kit For Stock Column DD Shaft	SC-295-DD	300.00
67-68 Mustang Manual Rack Steering Kit For Stock Column DD Shaft	SC-296-DD	300.00
Motor Mount Stands for Small Block Ford, Pair	MM-130	89.00
Rubber Motor Mounts for Small Block Ford, Pair	MM-135	89.00
67-70 Mustang Brake Pedal Kit for Automatic Trans	DP-001	170.00
67-70 Mustang Brake Pedal Kit for Manual Trans	DP-002	170.00
60-65 Falcon Inner Fender Panels	PX-328	70.00



MP-050



PX-325



DP-001

DP-002



MP-034



MM-130



MM-135



SB-065



Order/Tech: 800-841-8188

HEIDTS® MUSCLE CAR PARTS

64 1/2 - 70 MUSTANG FOR HEIDTS SUPERIDE® II

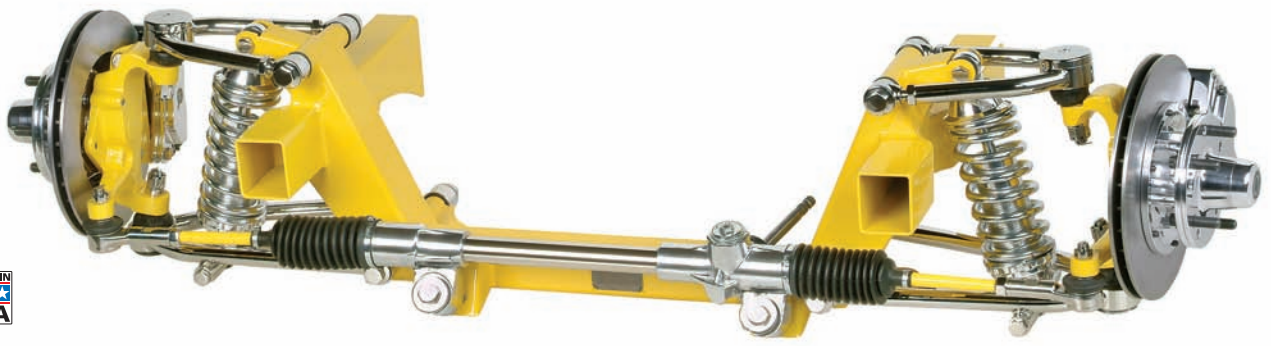

***Note:** These kits all require the use of a Rear Sump Style Oil Pan, and some Ford engines may require the use of a High-rise Hood to clear the intake system! Also, Ford 351 Clevelands will fit using dry sump with our kits! *Air bags will not fit.

Product is painted for catalog purposes only! All kits ship with Silver Powder Coated Springs - not shown.

COMPLETE BASE KIT STARTING AT \$3,455

INCLUDED IN BASE KIT:

- HEIDTS® Crossmember and Boxing Plates • 2" Dropped Spindles • Tubular Upper & Lower Arms • Manual Rack & Pinion Steering • 11" Rotors with 4 Piston Wilwood Calipers • Billet Single Adjustable Coil-Over Shocks with Silver Powder Coated Springs

Now with Silver Powder Coated Springs! Powder coating does not rust or peel while saving you money!



BX-340



BS-026

BS-002-XX

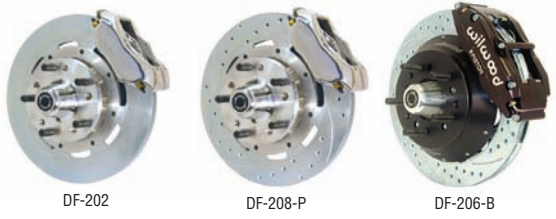

DF-202

DF-208-P

DF-206-B



MP-038-3-K

COMPLETE BASE KIT

Description	Part#	Base Price
64 1/2 - 70 Mustang & 67 - 70 Cougar	BX-340	3,455.00

CONTROL ARM OPTIONS

Description	Part#	Add
Tubular Arms (Narrowed available)	BS-025	Included
Stainless Steel Tubular Arms (Narrowed available)	BS-026	1,345.00

BRAKE OPTIONS

Description	Part#	Add
11" Iron Rotors & 4 Piston Black or Polished Calipers	DF-202	Included
12" Wilwood Drilled Rotors & 4 Piston Black, Polished Calipers	DF-208-P-K or B-K	686.00
13" Wilwood Drilled Rotors & 6 Piston Black, Polished Calipers	DF-206-B-K	1,734.00

Additional options available. Call for pricing.

RACK & PINION OPTIONS

Description	Part#	Add
Manual Rack & Pinion	MP-018-K	Included
Power Rack & Pinion	MP-038-3-K	140.00
Power Rack W/ Stainless Steel Tie Rod Ends	MP-038-SS-K	275.00

SPINDLE OPTIONS

Description	Part#	Add
2" Dropped Spindles	SP-101-K	Included

SHOCK & SPRING OPTIONS

Description	Part#	Add
400#, 450#, 500#, 550# Springs/Plain Billet Coil-Over Shocks	BS-001-XX	Included
400#, 450#, 500#, 550# Springs/Polished Billet Coil-Over Shocks	BS-002-XX	86.00
Thrust Bearings For Coil-Over Shocks	CQ-010	40.00
Spanner Wrench	TA-001	18.00

ADDITIONAL OPTIONS

Description	Part#	Price
Plain Swaybar (Narrowed available)	BS-061	204.00
Chrome Swaybar (Narrowed available)	BS-061-C	481.00
Polished Stainless Steel Balljoint Caps	MP-034	66.00
64-66, 67-70 Mustang Inner Panels	PX-325, PX-326	70.00
64-66 Mustang 36 Spline Power Rack Steering Kit For Stock Column	SC-290-DD	373.00
64-66 Mustang Manual Rack Steering Kit For Stock Column DD Shaft	SC-291-DD	373.00
67-68 Mustang 36 Spline Power Rack Steering Kit For Stock Column	SC-295-DD	300.00
68-68 Mustang Manual Rack Steering Kit For Stock Column DD Shaft	SC-296-DD	300.00
Motor Mount Stands for Small Block Ford, Pair	MM-131	89.00
Rubber Motor Mounts for Small Block Ford, Pair	MM-135	89.00
67-70 Mustang Brake Pedal Kit for Automatic Trans, Manual Trans	DP-001, 002	170.00

Owner & Builder:
Stang-Aholics



'64 1/2- '70 MUSTANG, '60-'65 FALCON

Bolt-In Rear HEIDTS PRO-G® 4-Link Kit



Bolt on maximum performance for your Mustang or Falcon. Kit includes chassis and axle brackets, adjustable links, full upper coil-over crossmember, panhard bar, adjustable HEIDTS® coil-overs and all hardware. Completely bolt-on, with no cutting or floor modifications. Adjustable 4-link mounts allow suspension tuning. Axle housing with brackets installed also available.

COMPLETE BASE KIT STARTING AT \$1,507

COMPLETE 4-LINK BASE KIT

Description	Part#	Base Price
64 1/2 - 70 Mustang	RM-101	1,507.00
64 1/2 - 70 Mustang	RM-101-PG	1,607.00
60 - 65 Falcon	RF-101	1,507.00
67-70 Cougar	RG-101-PG	1,674.00

LINKS & HARDWARE

Description	Part#	Add
64 1/2 - 70 Mustang Plain Links and Panhard Bar	RM-104	Included
60 - 65 Falcon Plain Links and Panhard Bar	RF-104	Included
64 1/2 - 70 Mustang Polished Stainless Steel Links and Panhard Bar	RM-106	748.00
60 - 65 Falcon Polished Stainless Steel Links and Panhard Bar	RF-106	748.00

SHOCK & SPRING OPTIONS

Description	Part#	Add
Black Coil-Over Shocks	CO-101	Included
250#, 300#, 350# Black Coil Springs	CR-XXX-11-B	Included
Billet Coil-Over Shocks/Silver Powder Coated Springs	CB-105	173.00
250#, 300#, 350# Silver Powder Coated Coil Springs	CR-XXX-11-C	Included
Thrust Bearings For Coil-Over Shocks	CQ-010	40.00
Spanner Wrench	TA-001	18.00

REAR AXLE HOUSING WITH BRACKETS

Description	Part#	Price
64 1/2 - 66 Mustang/60-65 Falcon Housing - 58" Track Width	RM-040-58-H	809.00
67-70 Mustang Stock/Race - 59" Track Width	RM-040-59-H	809.00

HEAVY DUTY AXLE OPTIONS

Description	Part#	Price
64-66 Mustang/60-65 Falcon 31 Spline Axles, 58" Track Width	RM-041-31	653.00
67-70 Mustang Stock/Race - 59" Track Width	RM-043-31	653.00

3RD MEMBER OPTIONS

Description	Part#	Price
Open 31 Spline 3.00, 3.25, 3.50, 3.70, 3.90, 4.11 Ratio	BN-XXX-I	766.00
Positraction 31 Spline 3.00, 3.25, 3.50, 3.70, 3.90, 4.11 Ratio	BN-XXX-I-L	1,296.00

BRAKE OPTIONS

Description	Part#	Price
11" Heavy Duty Drum Brake	RN-054	630.00
12" Iron Rotors, GM Single Piston Calipers W/Parking Brake	DR-005-E-P	753.00
12" Wilwood Smooth Rotors & 4 Piston Black Calipers W/Parking Brake	DR-005-P-B	766.00
12" Wilwood Smooth Rotors & 4 Piston Red Calipers W/Parking Brake	DR-005-P-RED	861.00
12" Wilwood Smooth Rotors & 4 Piston Polished Calipers W/Parking Brake	DR-005-P	842.00
12" Wilwood Drilled Rotors & 4 Piston Black Calipers W/Parking Brake	DR-005-P-D-B	845.00
12" Wilwood Drilled Rotors & 4 Piston Red Calipers W/Parking Brake	DR-005-P-D-RED	945.00
12" Wilwood Drilled Rotors & 4 Piston Polished Calipers W/Parking Brake	DR-005-P-D	958.00

STIFFENER & CONNECTOR OPTIONS

Description	Part#	Price
Rear Sway Bar	SB-016	303.00
Chassis Stiffener - Coupe or Fastback	RM-023	286.00
Subframe Connectors - Mustang Coupe or Fastback	RM-102	259.00
Subframe Connectors - Mustang Convertible	RM-103	259.00
Subframe Connectors - Falcon - Coupe Only	RF-102	259.00
Subframe Connectors - Mustang Coupe or Fastback, weld-in, plated	KB-29005	269.00
Jacking Rails - Mustang Coupe or Fastback	KB-28009	86.00
Extreme Matrix Brace - Mustang Coupe or Fastback	KB-28039	290.00
Extreme Matrix Kit - Mustang Coupe or Fastback	KB-29553	643.00



Product is painted for catalog purposes only! All kits ship with Silver Powder Coated Springs - not shown.

*Note: Will not fit Falcon convertible, Ranchero or Cougar.

INCLUDED IN BASE KIT:
• 4-Links and Axle Brackets • Top Crossmember • Panhard Bar • Standard Coil-Over Shocks, Black Body and Black Springs

Now with Silver Powder Coated Springs! Powder coating does not rust or peel while saving you money!



Gen I Extreme Matrix Kit - KB-29553
Includes - KB-29005, KB-28009, KB-28039



Order/Tech: 800-841-8188

HEIDTS® MUSCLE CAR PARTS

Owner & Builder:
Stang-Aholics



'64 1/2 - '70 MUSTANG - TRACK WIDTH 56 3/8"

HEIDTS PRO-G FULL FRONT SUSPENSION

Now with Silver Powder Coated Springs! Powder coating does not rust or peel while saving you money!



2" Dropped Spindle
Part of this high performance suspension package. Make your Nova handle like a 600 HP Go-Kart!



Suspension

True High Performance purpose designed suspension. A true race car designed geometry, not a warmed-over street rod suspension.

Product is painted for catalog purposes only! All kits ship with Silver Powder Coated Springs - not shown.

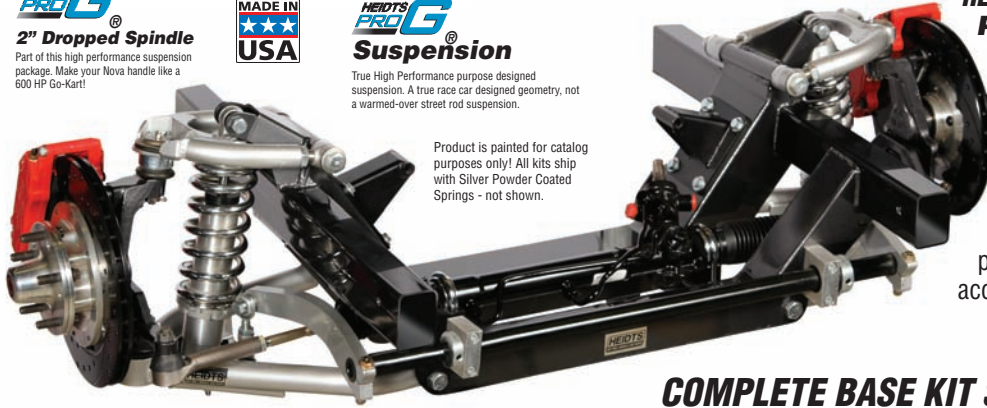

HEIDTS® now offers their **HEIDTS Pro-G®** full suspension package for early Mustangs. This Pro-Touring front end will give your car unbelievable cornering and handling. This kit includes everything you need to transform your Mustang. Kit includes: fully adjustable tubular control arms, Wilwood disc brakes, power rack & pinion, and motor mounts that will accept any of the popular Ford engines.

COMPLETE BASE KIT STARTING AT \$5,092

COMPLETE BASE KIT

Description	Part#	Base Price
64 1/2 - 70 Mustang	MTF-101	5,092.00
67 - 70 Cougar	MTF-101	5,092.00

CONTROL ARM OPTIONS

Description	Part#	Add
Plain Control Arms	CF-102	Included
Plain Control Arms 8" Addl. Positive Caster (optional)	CF-102-8-H	Included
Polished Stainless Steel Control Arms	CF-103	\$1,879.00

SPINDLE OPTIONS

Description	Part#	Add
2" Dropped Spindles	SP-110	Included

BRAKE OPTIONS

Description	Part#	Add
11" Wilwood Rotors & 4 Piston Black Calipers	DF-221-B	Included
12" Wilwood Drilled Rotors & 4 Piston Black Calipers	DF-222-D-B	465.00
13" Wilwood Drilled Rotors & 6 Piston Black, Polished Calipers	DF-223-D-B	1,685.00

Additional options available. Call for pricing.

RACK & PINION OPTIONS

Description	Part#	Add
Power Rack with 17mm "DD" Input Shaft	OPR-1-D-K	Included

SHOCK & SPRING OPTIONS

Description	Part#	Add
Plain Billet /coil-Over Shocks	CB-160	Included
400#, 450#, 500#, 550# Silver Powder Coated Springs	CX-XXX-10	Included
Thrust Bearings For Coil-Over Shocks	CQ-010	40.00
Spanner Wrench	TA-001	18.00

ADDITIONAL OPTIONS

Description	Part#	Price
64-66 Mustang Steel Inner Fender Panels	PX-325	70.00
67-70 Mustang Steel Inner Fender Panels	PX-326	70.00
Swaybar 1 1/4 Splined	SB-403	702.00
1" Swaybar	SB-112-K	215.00
Upper Arm "Heim Style" Adjuster Kit	CF-104	213.00



DF-222-D-P



DF-223-D-B



SP-110



CB-160



SP-110



PX-325

'64 1/2 - '70 MUSTANG



Owner & Builder:
Stang-Aholics

HEIDTS PRO-G[®] IRS

Now with Silver Powder Coated Springs! Powder coating does not rust or peel while saving you money!

HIGH HORSEPOWER INDEPENDENT REAR SUSPENSION

U.S. Patent No. D666,949
Additional Patents Pending

WHY HEIDTS PRO-G[®] IRS



Do you really want to go fast and out-handle everyone else on the autocross or road race course in your Mustang? Full independent rear suspension is the only way to go. HEIDTS[®] now has a High Horsepower Independent Rear Suspension bolt-In Package that will do the job just fine.

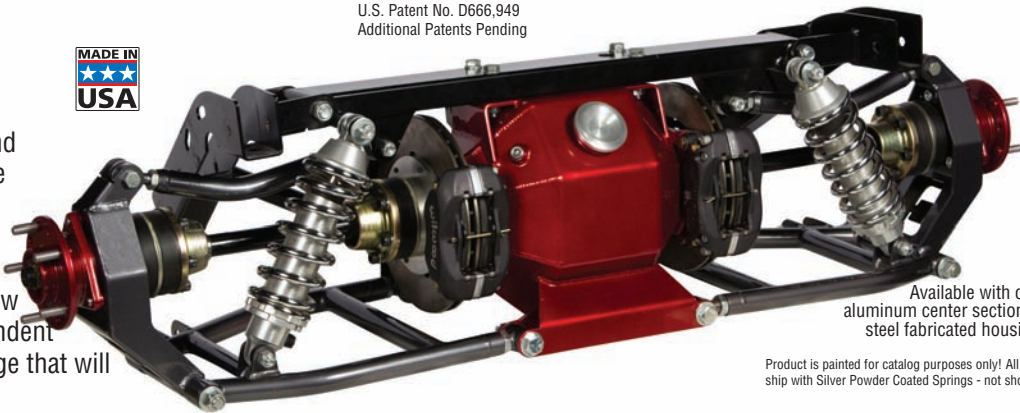

Available with cast aluminum center section or steel fabricated housing.

Product is painted for catalog purposes only! All kits ship with Silver Powder Coated Springs - not shown.

It is a true high horsepower package, with upper links and heavy duty CV joints. The upper link produces -5° of camber curve at 3/4 of total travel during very high cornering loads. Forward struts, attached to the sub-frame connectors insures the wheels stay in place during hard acceleration.

COMPLETE BASE KIT

Description	Part#	Base Price
64 1/2 - 70 Mustang High Horsepower IRS - Plain Rotors	IRM-101	9,320.00
64 1/2 - 70 Mustang High Horsepower IRS - Drilled & Slotted Rotors	IRM-101-S	9,654.00

SHOCK & SPRING OPTIONS

Description	Part#	Price
Plain Billet Coil-Over Shocks	CB-106	Included
350# Silver Powder Coated Springs w/CB-106	CR-350-11-C	Included
400# Silver Powder Coated Springs w/CB-106	CR-400-11-C	Included
450# Silver Powder Coated Springs w/CB-106	CR-450-11-C	Included
550# Silver Powder Coated Springs w/CB-106	CR-450-11-C	Included

3RD MEMBER OPTIONS

Description	Part#	Price
Positraction 31 Spline 3.00 Ratio	BN-300-I-L	Included
Positraction 31 Spline 3.25 Ratio	BN-325-I-L	Included
Positraction 31 Spline 3.50 Ratio	BN-350-I-L	Included
Positraction 31 Spline 3.70 Ratio	BN-370-I-L	Included
Positraction 31 Spline 3.90 Ratio	BN-390-I-L	Included
Positraction 31 Spline 4.11 Ratio	BN-411-I-L	Included

SUBFRAME CONNECTOR

Description	Part#	Price
64 1/2 - 70 Mustang Subframe Connectors - Coupe	RM-102-IRM	Included
64 1/2 - 70 Mustang Subframe Connectors - Convertible	RM-103-IRM	Included

PARKING BRAKE OPTIONS

Description	Part#	Price
Parking Brake Kit & Cable Kit	PB-101	589.00
E-Stop Actuator	BM-013	699.00

HOUSING OPTIONS

Description	Part#	Add
Polished Aluminum 9" Housing	BM-001-P	205.00
Steel Fab 9" Housing	BT-410	

COMPLETE BASE KIT STARTING AT \$9,320



*Subframe Connectors Included.



WHAT YOU GET:

- Track Width 56 1/2"
- 9" Aluminum HSG.
- 3rd Member, Iron, Posi
- CV Joint Halfshafts
- Tubular Upper & Lower Arms
- Steel Outer Uprights
- Top Crossmember
- Frame Mounting Brackets
- Front Pinion Support
- Forward Struts*
- 10.5" Wilwood Rotors
- Black Wilwood Calipers
- Billet Single Adjustable Coil-Overs with Silver Powder Coated Springs
- Posi-Traction

OPTIONS: CALL FOR DETAILS.

- Choice of Gear Ratios
- Parking Brake Kit and Cable Kit



"About once every ten years, someone comes up with a breakthrough part in the aftermarket. The HEIDTS[®] Bolt-in Independent Rear suspension could be that part for 2011 and beyond!"

Quoted from Jim Campisano - Editor Super Chevy Magazine, January Issue



Order/Tech: 800-841-8188

HEIDTS[®] MUSCLE CAR PARTS



2005-2014 MUSTANG

Advanced Geometry Suspension System 4.0



AGS 4.0 "SUPER-GRIP" FRONT LOWER CONTROL ARM MODULE

Description	Part#	Price
2005 -2009 Mustang and GT500. Patent Pending.	KB-49721	787.00
2010-2014 Mustang and GT500 Patent Pending.	KB-49731	787.00

The Kenny Brown AGS 4.0 "Super Grip" Front Lower Control Arm Module completely transforms the handling and driving dynamics of your S197 Mustang or Shelby GT500. A critical element to the AGS 4.0 Front Suspension System is the computer designed "Super Grip" Front Lower Control Arms. They give you precision and performance in an easy-to-install, street friendly package.

AGS 4.0 LIGHT-WEIGHT TUBULAR FRONT K-MEMBER

Description	Part#	Price
2005-2014 Mustang and GT500	KB-49710	808.00

Strongest, Best Engineered, Bolt-In K-Member Available.

- Designed to work with our exclusive Super-Grip AGS 4.0 control arms
- Reduces front weight for better vehicle balance
- Rugged Tubular Design

ADJUSTABLE REAR CONTROL ARMS

Description	Part#	Price
Street/Sport (Single adjustable Rod-End and urethane)	KB-28661	272.00
Track/Sport (Double adjustable Rod-Ends)	KB-28660	314.00

A Kenny Brown exclusive - offsets spacers straighten control arms bringing them parallel to center line, correcting rear roll axis.

- Fits 2005-2014 Mustang and GT500
- Improves grip, handling, and control
- Less deflection and more grip
- Light-weight, heavy-duty design
- Low-friction bushings and competition-grade rod ends

NOTE: We recommend you pair the Adjustable Rear Lower Control Arms with the AGS 4.0 Anti-Squat Traction Brackets (KB-28601) to maximize performance, grip and braking.

ANTI-SQUAT TRACTION BRACKETS

Description	Part#	Price
2005-2014 Mustang and GT500	KB-28601	142.00

Another critical element in the Kenny Brown AGS Suspension System, the Anti-Squat Traction Brackets let you put the power to the ground with more control, traction, grip and braking for serious high-performance driving. For maximum performance Kenny Brown recommends adding Adjustable Rear Lower Control Arms (KB-28661 or KB-28660) and AGS 4.0 Upper Control Arm Module (KB-28665).



AGS 4.0 - The Best Complete Late-Model Suspension Solution

ROLL CENTER RELOCATION KIT WITH HEAVY-DUTY DOUBLE ADJUSTABLE PANHARD BAR

Description	Part#	Price
2005-2014 Mustang and GT500	KB-28620	523.00

A lower rear roll center has been part of Kenny's AGS suspension systems since the early '90's and further refined for the new 2005-2014 Mustangs and GT500's.

- Dramatically improves handling
- Adjustable mounting brackets for lower ride height
- Double-Adjustable Panhard Bar with competition-grade rod ends
- MUST HAVE for street performance

HEAVY DUTY REAR ADJUSTABLE PANHARD BAR - STREET SPORT

Description	Part#	Price
2005-2013 Mustang and GT500 Street/Sport – adjustable with urethane/rod end	KB-28630	209.99
2005-2013 Mustang and GT500 GT4 Track/Sport – double adjustable with double rod ends	KB-28631	188.00

Keep Your Axle Centered for Improved Handling.

- Designed to replace the OEM panhard bar
- Heavy Duty Design
- Low-friction bushings and competition-grade rod-ends
- Track/Sport is double adjustable with two HD rod-ends

Lowering Mustangs with the "fixed length" factory Panhard Bar tends to shift the axle to one side.

U-LINK REAR UPPER CONTROL ARM MODULE - STREET/COMP

Description	Part#	Price
2005-2009 Mustang and GT500	KB-28665	419.00
2010-2014 Mustang and GT500	KB-28675	419.00

- Improves critical aspects of the rear suspension geometry
- Improves anti-squat/ anti-lift
- Lightweight, heavy-duty design for increased strength
- Critical part of the AGS 4.0 Suspension System
- A "MUST-HAVE" for all lowered Mustangs and street performance driving

The U-Link upper control arm module is a critical part of this AGS 4.0 rear suspension package. Kenny Brown lengthened the upper control arm to reduce SVSA (side-view swing arm) instant center migration for more stable and predictable handling, grip and braking.





The Ultimate in Under Car Chassis Support



KB-29550



KB-29004



KB-28010



KB-28019

EXTREME MATRIX KIT

Description	Part#	Price
1994-2004 Mustang GT, V6 & Cobra* (kit includes KB-29004, KB-28010, KB-28019)	KB-29550	472.00
1979-1993 Fox Mustang GT, V6 & Cobra (kit includes KB-29004, KB-28009, KB-28019)	KB-29551	472.00
2005-2014 Mustang, GT500 (kit includes KB-28009, KB-28029 – note: does not include 29004)	KB-29552**	272.00

* 96-98 Cobra - Subframe Connectors must be modified by shortening slightly.
 **2005-2014 Mustangs, GT500 do not need subs to install Extreme Matrix Brace.

The Kenny Brown Extreme Matrix Kit improves the ride quality and handling of your Mustang by maximizing the strength of the car's center pan section, with minimum additional weight and no loss in ground clearance. The Extreme brace "bridges" the Subframe Connectors** and Jacking Rails to form a triangulated 12" wide frame on each side of your Mustang. Finished in OE-quality, silver zinc chromate for rust protection.

DOUBLE-CROSS SUBFRAME CONNECTORS

Description	Part#	Price
1979-2004 Mustang GT, V6 and Cobras*	KB-29004	134.00

* 96-98 Cobra - Subframe Connectors must modify by shortening slightly.

The Kenny Brown industry leading Double-Cross Subframe Connectors dramatically reduce power-robbing chassis flex by uniting the front and rear subframes. The double-cross design reduces the twisting action of the floor pan by cutting the free span of the car in half by attaching the cross section of the Subframe Connectors to the Mustang's mid-pan. Improves handling, feel, and weight transfer; strengthens the unibody and extends the life of your Mustang. Finished in OE-quality, silver zinc chromate for rust protection.

JACKING RAILS

Description	Part#	Price
2005-2014 Mustang, GT500*; 1979-1993 Mustang GT, V6 and Cobra	KB-28009	83.00
1994-2004 Mustang GT, V6 and Cobra	KB-28010	83.00

* Requires modification.

Kenny Brown Jacking Rails lets you safely and quickly jack up your Mustang any place along the rocker panel under the doors. Prevents deformation of the front subframe rails and floor pan commonly experienced with jack use. Adds additional rigidity and structural integrity to the chassis. A must for all lowered Mustangs. It's quick, easy, and simple to install. Finished in OE-quality, silver zinc chromate for rust protection.

EXTREME MATRIX BRACE

Description	Part#	Price
1979-2004 Mustangs and Cobras	KB-28019	250.00
2005-2014 Mustangs, GT500	KB-28029**	250.00

Note: The Extreme Matrix Brace cannot be installed independently. Needs Kenny Brown Super Subs and Jacking Rails for proper attachment.

**2005-2014 Mustangs, GT500 do not need subs to install Extreme Matrix Brace. Will not fit convertibles.

The Kenny Brown Extreme Matrix Brace improves the ride quality and handling of your Mustang by maximizing the strength of the car's center pan section, with minimum additional weight and no loss in ground clearance. The brace works in conjunction with the the Subframe Connectors** and Jacking Rails to form a triangulated 12" wide frame on each side of your Mustang! Finished in OE-quality, silver zinc chromate for rust protection.



Number One in Mustang Chassis Support

3-PT HEAVY-DUTY STRUT TOWER BRACE

Description	Part#	Price
1999-2004 Mustang GT / '99-'01 Cobra / '99-'04 V-6	KB-29302	199.00
2003-2004 Mach 1 Mustang	KB-29403	294.00
2003-2004 Cobra	KB-29501	209.00

The Kenny Brown 3-pt Heavy-Duty Strut Tower Brace increases the strength and rigidity of the upper portion of the engine bay and front suspension by reinforcing the strut towers to the firewall giving ride quality and handling a huge boost. This extra rigidity manages chassis loads from engine torque for better handling and performance under hard cornering, sudden starts, sudden stops and abrupt directional changes.



2-PT HEAVY-DUTY STRUT TOWER BRACE

Description	Part#	Price
Fits 2005 -2014 Mustang GT & V-6	KB-29601	115.00

Note: Will not fit GT500 w/supercharger

The Kenny Brown 2-Point Heavy-Duty Strut Tower Brace substantially increases the strength and rigidity of the engine bay and front suspension by reinforcing the shock towers, giving ride-quality and handling a huge boost. The heavy-duty design allows the front suspension to better manage the stress loads generated from hard cornering, while also allowing the chassis to better manage the loads from twisting under hard launch.



2-PT LOWER CHASSIS BRACE

Description	Part#	Price
2005 -2014 Mustang and Shelby GT500	KB-29405	104.00

The Kenny Brown 2-Point Lower Chassis Brace substantially increases the strength and rigidity of the frame and K-member mounting points. The brace allows the chassis to better manage the loads generated from hard cornering and from twisting under hard launch. A much needed addition for road racing applications where alignment accuracy and consistency are critical to optimal performance.



REAR SHOCK TOWER BRACE

Description	Part#	Price
1994-2004 Mustang GT, V6 and Cobra	KB-29901	157.00
2005-2014 Mustang, Shelby GT500	KB-29902	157.00

Note: May fit 1979-1993 Mustang w some adjustments.

The Kenny Brown Heavy-Duty Rear Shock Tower Brace adds rigidity and strength to the rear shock tower through triangulated reinforcement of the shock tower, capturing torsional loads directly over the rear axle for improved handling weight transfer and grip. Improve handling and performance under hard cornering and abrupt directional changes.





Kenny Brown AGS 3.0 Front Suspension 1979-2004 Mustang/Cobra

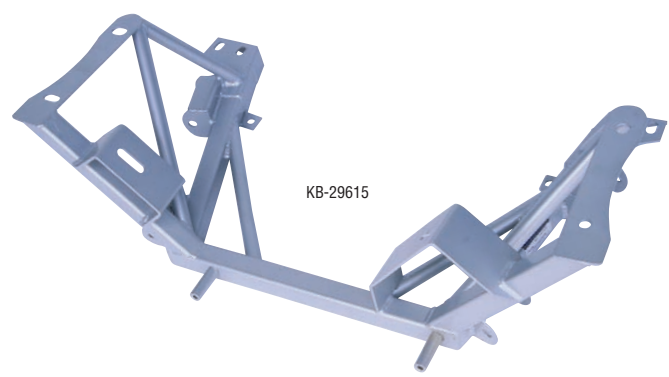

KB-29615

LIGHT-WEIGHT TUBULAR FRONT K-MEMBER

Description	Part#	Price
1996-2004 Mustang and Cobra* 4.6L engines	KB-49610	953.00
1994-2004 Mustang and Cobra** 5.0L OHV engines.	KB-49615	953.00

- * `99-`04 4.6L Cobras need oil filter relocation kit
- ** Requires coil-over strut/spring package
- ** May require modifications for proper fitment on `79-`93 models

The Kenny Brown Advanced Geometry Tubular K-Member optimizes our "fixed strut" advanced geometry suspension design for superior handling, grip, and braking with a distinct European sports car performance feel. The Tubular K-member reduces overall weight by 40 pounds over factory and improves weight distribution and balance by extending the wheelbase forward by one inch improving the roll center envelope, camber gain, toe curve greatly improving the handling performance. Designed to be used in conjunction with the Kenny Brown Tubular Front Lower Control Arms and coil-over shock package.

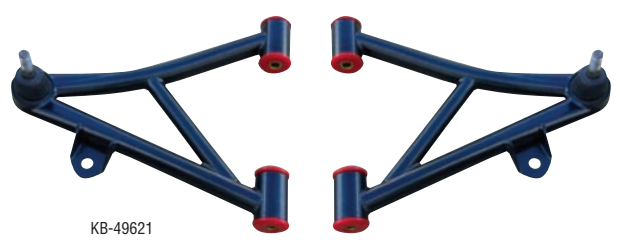

KB-49621

TUBULAR FRONT LOWER CONTROL ARMS WITH LOW-FRICTION BALL JOINTS

Description	Part#	Price
1979-2004 Mustang and SVT Cobra	KB-49621	556.00

- * Requires coil-over strut/spring package
- * May require minor modifications for proper fitment on some older models

The Kenny Brown Advanced Geometry Tubular Front Lower Control Arms offers a significant reduction in weight with increased rigidity for improved suspension response. The Control Arms are a direct OEM replacement and allow for coil-over front struts on 1979-2004 Mustangs and Cobras. Choice of ball joints. Competition ball joints allow fine tuning adjustments in roll-center height.



KB-490042

CASTER PLUS UPPER STRUT MOUNT KIT

Description	Part#	Price
1994-2004 Mustangs and Cobra	KB-49041	157.00
1987-1993 Mustang and Cobra	KB-49042	157.00

The Kenny Brown Caster Plus Upper Strut Mount Kit keeps your car pointed in the right direction whether you're blasting down the straights, turning hard into the apex, powering out of the corner exit or heading home from work - without the noise, hassle or high cost of other common strut mounts kits. Our design relocates the upper strut mounting point for maximum caster while providing the full range of camber adjustment enhancing the front camber curve and totally changing the dynamics of the front suspension. Dramatically improving cornering ability, high-speed and directional stability, while providing sharp cornering ability by maximizing the "foot print" of the tire under all demands.



KB-80503

ADJUSTABLE HEAVY-DUTY FRONT SWAY BAR

Description	Part#	Price
1994-2004 Mustang and Cobra	KB-80503	403.00
Sway Bar Endlinks fits 1994-2004 Mustang and Cobra Endlinks specific to Kenny Brown front control arms or stock control arms	KB-80603	73.00

Note: Requires Sway Bar Endlink Kit, KB-80603

The medium-firm Front Sway Bar that Kenny Brown uses on all of his street and track cars dramatically improves the handling of your Mustang. The Front Sway Bar reduces body roll and increases front grip. Exceptional for track applications.



Advanced Geometry Suspension 3.0 Cobra IRS/ Mustang Live Axle

IRS REAR UPPER CONTROL ARMS

Description	Part#	Price
1999-2004 Cobra	KB-49530	892.00

The Kenny Brown IRS Rear Upper Control Arms offers improved suspension response and "bite" through a significant reduction in weight and increased strength. Features urethane bushings at the chassis end.



KB-49530

IRS REAR LOWER CONTROL ARMS

Description	Part#	Price
Fits 1999-2004 Cobra	HKB-49520*	682.00

*Must convert to coil-over shocks

The Kenny Brown IRS Rear Lower Control Arms put the power to the ground with more control through improved suspension response. Features urethane bushings. Significant weight reduction and increased strength.



KB-49520*

IRS FORWARD TORQUE BRACE

Description	Part#	Price
Fits 1999-2004 Cobra	KB-29600	157.00

The Kenny Brown IRS Forward Torque Brace helps reduce wheel hop experienced in IRS cars by controlling the torque-induced reflex deflection on the IRS carrier at the driveshaft, improving traction and overall handling of your Cobra.



KB-29600

IRS ALUMINUM DIFFERENTIAL BUSHING KIT

Description	Part#	Price
1999-2004 Cobra	KB-87011	94.00
Urethane O.E. Replacement Bushings	KB-87001	57.00

Helps reduce wheel hop, adjusts pinion angle.



KB-87011

IRS REAR STEER KIT FOR 1999-2004 SVT COBRA

Description	Part#	Price
1999-2004 Cobra	KB-49550	209.00

The Kenny Brown IRS Rear Steer Kit is designed to dramatically reduce the amount of "rear steer" induced by rear body roll under hard cornering. Adds stability and improves handling and grip.



KB-49550

ADJUSTABLE REAR UPPER CONTROL ARMS

Description	Part#	Price
1979-2004 Mustang, 1993-1998 Cobra	KB-28050	313.00



KB-28050

KB-49001

ANTI-SQUAT TRACTION BRACKETS

Description	Part#	Price
1979-2004 Mustang and 1993-1998 Cobra	KB-49001	142.00

Dramatically improves traction, grip, and braking.

ADJUSTABLE REAR LOWER CONTROL ARMS

Description	Part#	Price
Fits 1979-2004 Mustang, 1993-1998 Cobra	KB-28061CO*	435.00

* Must convert to coil-over shocks



KB-28061CO*

HEIDTS SUPERIDE® II IFS

***LOWERS VEHICLE 2"**

'66 - '67 FAIRLANE/COMET HEIDTS SUPERIDE® II FRONT SUSPENSION

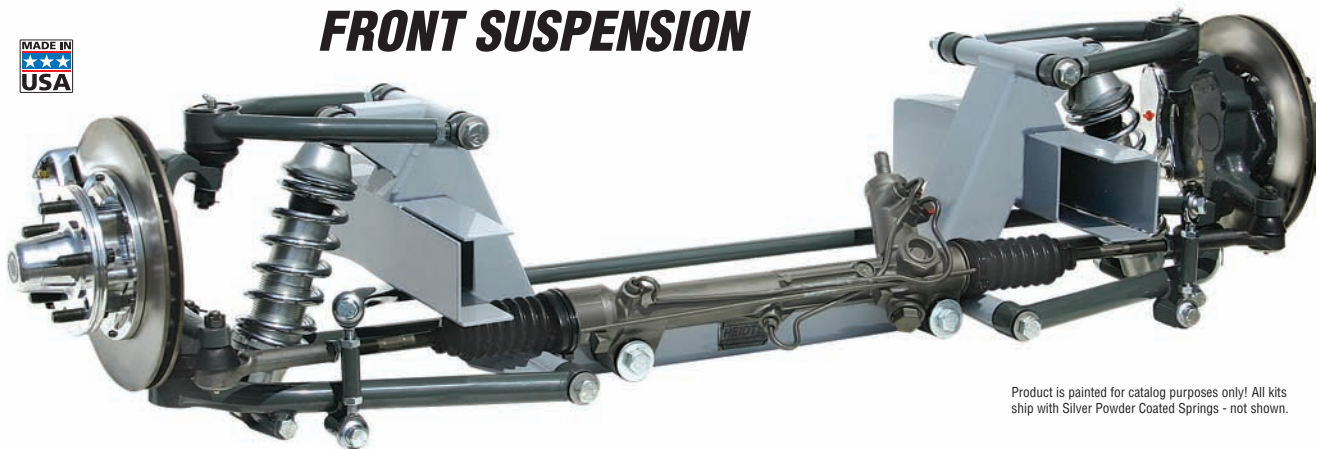

Product is painted for catalog purposes only! All kits ship with Silver Powder Coated Springs - not shown.

INCLUDED IN BASE KIT:

- HEIDTS® Crossmember and Boxing Plates • Spindles
- Tubular Upper & Lower Arms • Power Rack & Pinion Steering • 11" Rotors with 4 Piston Wilwood Calipers
- Billet Single Adjustable Coil-Over Shocks with Silver Powder Coated Springs

Now with Silver Powder Coated Springs! Powder coating does not rust or peel while saving you money!

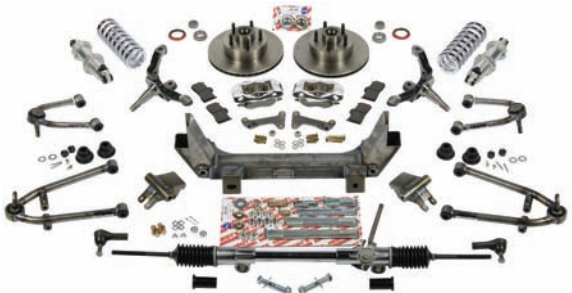

COMPLETE BASE KIT

Description	Part#	Base Price
66-67 Fairlane / 66-67 Comet	BX-601	3,575.00

BRAKE OPTIONS

Description	Part#	Add
11" Iron Rotors & 4 Piston Black or Polished Calipers	DF-202-C-B or C-P	Included
12" Wilwood Drilled Rotors & 4 Piston Black, Polished Calipers	DF-208-P-K	686.00
13" Wilwood Drilled Rotors & 6 Piston Black Calipers	DF-206-B-K	1,734.00

Additional options available. Call for pricing.

CONTROL ARM OPTIONS

Description	Part#	Add
Tubular Arms (Narrowed available)	BS-021-RS	Included
Stainless Steel Tubular Arms (Narrowed available)	BS-022-RS	1,291.00

SPINDLE OPTIONS

Description	Part#	Add
Stock Spindles Recommended	MP-028	Included
2" Dropped Spindles	SP-101-K	Included

POWER RACK & PINION OPTIONS

Description	Part#	Add
Power Rack	MP-038-3-K-CT	Included
Chrome Power Rack	MP-038-C-K-CT	362.00

SHOCK & SPRING OPTIONS

Description	Part#	Add
400#, 450#, 500#, 550# Springs/Plain Billet Coil-Over Shocks	BS-001-XX	Included
400#, 450#, 500#, 550# Springs/Polished Billet Coil-Over Shocks	BS-002-XX	86.00
Thrust Bearings For Coil-Over Shocks	CQ-010	40.00
Spanner Wrench	TA-001	18.00

ADDITIONAL OPTIONS

Description	Part#	Price
Plain Sway Bar	SB-190	221.00
Small Block Ford Motor Mounts	MM-140	92.00
Steel Inner Fender Panels	PX-327	70.00

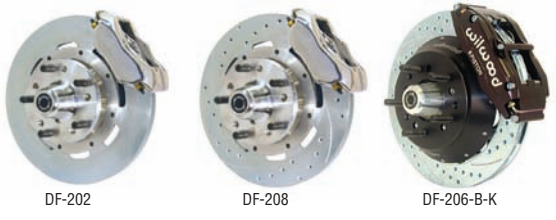

'66 - '67 FAIRLANE 66 - '67 COMET



LOWERS VEHICLE 2"

Bolt-In Rear 4-Link Kit

HEIDTS PRO-G® Rear 4-Link offers maximum performance for your Fairlane. Completely bolt-on, with no cutting or floor modifications. Adjustable 4-link mounts allow suspension tuning. Axle housing with brackets installed also available.

INCLUDED IN BASE KIT:

- Adjustable Links with Frame and Axle Brackets
- Full Upper Coil-Over Crossmember • Standard Coil-Over Shocks, Black Body and Black Springs

Now with Silver Powder Coated Springs! Powder coating does not rust or peel while saving you money!

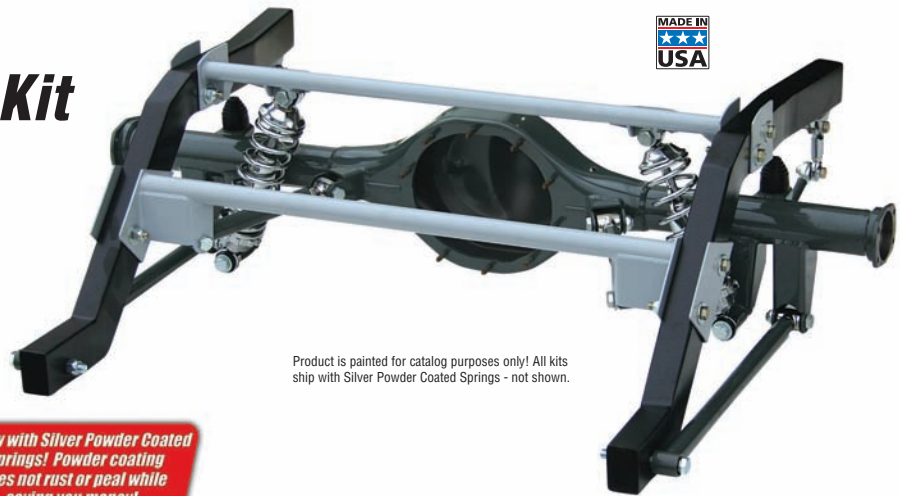

Product is painted for catalog purposes only! All kits ship with Silver Powder Coated Springs - not shown.

COMPLETE BASE KIT

Description	Part#	Base Price
66-67 Fairlane/Comet	RF-110	1,507.00

LINKS & HARDWARE

Description	Part#	Add
66-67 Fairlane/Comet Plain Links	RF-111	Included
66-67 Fairlane/Comet Polished Stainless Steel Links	RF-112	632.00

SHOCK & SPRING OPTIONS

Description	Part#	Add
Black Coil-Over Shocks	CO-101	Included
250#, 300#, 350# Black Coil Springs	CR-XXX-11-B	Included
Billet Coil-Over Shocks/Silver Powder Coated Springs	CB-105	173.00
250#, 300#, 350# Silver Powder Coated Coil Springs	CR-XXX-11-C	Included
Thrust Bearings For Coil-Over Shocks	CQ-010	40.00
Spanner Wrench	TA-001	18.00



REAR AXLE HOUSING

Description	Part#	Price
66-67 Fairlane/Comet Rear 9" Housing with Brackets	RF-115	802.00

HEAVY DUTY AXLE

Description	Part#	Price
31 Spline Axle -Ford Bolt Pattern - 60" Track Width	RM-042-31	653.00

3RD MEMBER OPTIONS

Description	Part#	Price
Open 31 Spline 3.00, 3.25, 3.50, 3.70, 3.90, 4.11 Ratio	BN-XXX-I	766.00
Positraction 31 Spline 3.00, 3.25, 3.50, 3.70, 3.90, 4.11 Ratio	BN-XXX-I-L	1,296.00



BRAKE OPTIONS

Description	Part#	Price
11" Heavy Duty Drum Brake	RN-054	630.00
12" Iron Rotors, GM Single Piston Calipers W/Parking Brake	DR-005-E-P	753.00
12" Wilwood Smooth Rotors & 4 Piston Black Calipers W/Parking Brake	DR-005-P-B	766.00
12" Wilwood Smooth Rotors & 4 Piston Red Calipers W/Parking Brake	DR-005-P-RED	861.00
12" Wilwood Smooth Rotors & 4 Piston Polished Calipers W/Parking Brake	DR-005-P	842.00
12" Wilwood Drilled Rotors & 4 Piston Black Calipers W/Parking Brake	DR-005-P-D-B	845.00
12" Wilwood Drilled Rotors & 4 Piston Red Calipers W/Parking Brake	DR-005-P-D-RED	945.00
12" Wilwood Drilled Rotors & 4 Piston Polished Calipers W/Parking Brake	DR-005-P-D	958.00



Order/Tech: 800-841-8188

'62-'67 NOVA SUBFRAME

'62-'67 NOVA SUBFRAME / CROSSMEMBER SUSPENSION PACKAGE AND ASSEMBLY



Now you can give your '62-67 Chevy Nova the lowered look and superior handling the street rods have enjoyed for years. HEIDTS® now offers their Front Suspension crossmembers and components for '62-'67 Novas to make it easy!

Product is painted for catalog purposes only! All kits ship with Silver Powder Coated Springs - not shown.



* Air bags will not fit.

CA-112-SS



DF-202



DF-208



DF-206-B-K



MP-038-3-K



MP-050



SP-101-K



CX-325

INCLUDED IN BASE KIT:

- HEIDTS® Front Subframe • Tubular Upper & Lower Arms • Stock Spindles • 11" Rotors with Single Piston Calipers • Manual Rack & Pinion Steering
- Stock Shocks and Springs

Now with Silver Powder Coated Springs! Powder coating does not rust or peel while saving you money!

COMPLETE BASE KIT STARTING AT \$2,862

COMPLETE BASE KIT

Description	Part#	Base Price
62-67 Nova	CX-320-S-K	2,862.00

CONTROL ARM OPTIONS

Description	Part#	Add
Tubular Arms (Narrowed available)	CA-112	Included
Stainless Steel Tubular Arms (Narrowed available)	CA-112-SS	1,188.00

SPINDLE OPTIONS

Description	Part#	Add
Stock Spindles	MP-028	Included
2" Dropped Spindles	SP-101-K	Included

BRAKE OPTIONS

Description	Part#	Add
11" Iron Rotors & GM Metric Calipers	DF-201-B-G or F-G	Included
12" Wilwood Drilled Rotors & 4 Piston Black, Polished Calipers	DF-208-P-K	1,127.00
13" Wilwood Drilled Rotors & 6 Piston Black, Black Calipers	DF-206-B-K	1,896.00

Additional options available. Call for pricing.

RACK & PINION OPTIONS

Description	Part#	Add
Manual Rack & Pinion	MP-018-1-K	Included
Power Rack & Pinion	MP-038-3-K	140.00
Power Rack W/ Stainless Steel Tie Rod Ends	MP-038-SS-K	275.00

SHOCK & SPRING OPTIONS

Description	Part#	Add
275# - 375# Springs & Stock Shocks	MP-007-XXX-K	Included
275# - 375# Springs & Coil-Over Shocks	MP-050-XXX-K	486.00
Thrust Bearings For Coil-Over Shocks	CQ-010	40.00
Spanner Wrench	TA-001	18.00

ADDITIONAL OPTIONS

Description	Part#	Price
62-67 Nova Swaybar	SB-060	258.00
Polished Stainless Steel Balljoint Caps, Pair	MP-034	66.00
62-65 Nova Steel Inner Fender Panels	CX-325	243.00
66-67 Nova Steel Inner Fender Panels	CX-326	243.00
62-66 Nova Stock Column to Power Rack	SC-246-DD	356.00
67 Nova Stock Column to Power Rack	SC-249-DD	356.00
62-66 Nova Stock Column to Manual Rack	SC-236-DD	356.00
67 Nova Stock Column to Manual Rack	SC-239-DD	356.00

'62-'67 NOVA HEIDTS SUPERIDE® II FOR SUBFRAME



INCLUDED IN BASE KIT:

- HEIDTS® Front Subframe • Tubular Upper & Lower Arms • Stock Spindles • 11" Rotors with 4 Piston Wilwood Calipers
- Manual Rack & Pinion Steering • Billet Single Adjustable Coil-Over Shocks

Now with Silver Powder Coated Springs! Powder coating does not rust or peel while saving you money!



COMPLETE BASE KIT STARTING AT \$3,796

COMPLETE BASE KIT

Description	Part#	Base Price
62-67 Nova	BX-320	3,796.00

CONTROL ARM OPTIONS

Description	Part#	Add
Tubular Arms (Narrowed available)	BS-025	Included
Stainless Steel Tubular Arms (Narrowed available)	BS-026	1,345.00

BRAKE OPTIONS

Description	Part#	Add
11" Iron Rotors & 4 Piston Wilwood Black or Polished Calipers	DF-202-C-B or C-P	Included
12" Wilwood Drilled Rotors & 4 Piston Black, Polished Calipers	DF-208-P-K	686.00
13" Wilwood Drilled Rotors & 6 Piston Black, Black Calipers	DF-206-B-K	1,734.00

Additional options available. Call for pricing.

SPINDLE OPTIONS

Description	Part#	Add
Stock Spindles	MP-028	Included
2" Dropped Spindles	SP-101-K	Included

SHOCK & SPRING OPTIONS

Description	Part#	Add
400#, 450#, 500#, 550# Springs/Plain Billet Coil-Over Shocks	BS-001-XX	Included
400#, 450#, 500#, 550# Springs/Polished Billet Coil-Over Shocks	BS-002-XX	86.00

RACK & PINION OPTIONS

Description	Part#	Add
Manual Rack & Pinion	MP-018-1-K	Included
Power Rack & Pinion	MP-038-3-K	140.00
Power Rack W/ Stainless Steel Tie Rod Ends	MP-038-SS-K	275.00

SUPPORT TUBE OPTIONS

Description	Part#	Add
Support Tubes With Shims	BX-321	Included
Adjustable Support Tubes	BX-322	135.00

ADDITIONAL OPTIONS

Description	Part#	Price
Plain Swaybar	BS-061	204.00
Chrome Swaybar	BS-061-C	481.00
62-65 Nova Inner Fender Panels	CX-325	243.00
66-67 Nova Steel Inner Fender Panels	CX-326	243.00
Polished Stainless Steel Balljoint Caps, Pair	MP-035	66.00
Rubber Motor Mounts for Small Block Chevy, Pair	MM-120	64.00
62-66 Nova Stock Column to Power Rack	SC-246-DD	356.00
67 Nova Stock Column to Power Rack	SC-249-DD	356.00
62-66 Nova Stock Column to Manual Rack	SC-236-DD	356.00
67 Nova Stock Column to Manual Rack	SC-239-DD	356.00



* Air bags will not fit.

Product is painted for catalog purposes only! All kits ship with Silver Powder Coated Springs - not shown.

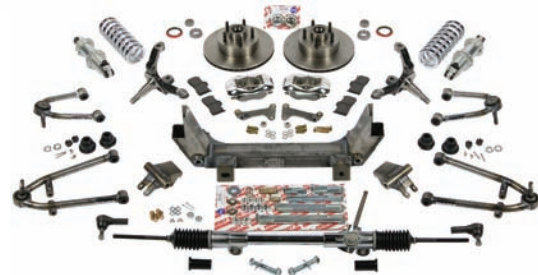

'62-'67 NOVA

TRACK WIDTH 56 3/8"

Owner/Builder:
Bill Jelinek
Route 66 Motorsports



HEIDTS PRO-G® '62-'67 BOLT-ON SUBFRAME

Now with Silver Powder Coated Springs! Powder coating does not rust or peel while saving you money!



HEIDTS PRO-G®
2" Dropped Spindle

Part of this high performance suspension package. Make your Nova handle like a 600 HP Go-Kart!

HEIDTS PRO-G®
Suspension

True High Performance purpose designed suspension. A true race car designed geometry, not a warmed-over street rod suspension.



Product is painted for catalog purposes only! All kits ship with Silver Powder Coated Springs - not shown.

Bolt on the best suspension possible for your '62-'67 Nova. **HEIDTS®** now offers their true bolt on Pro Touring full front subframe. Featuring their new **HEIDTS Pro-G®** Suspension package for unbelievable cornering and overall handling. Simply unbolt and remove your front sheetmetal, engine and trans, your old subframe, then slide in the new complete **HEIDTS®** Subframe. Reinstall your fresh engine, reinstall your sheetmetal and you are set to tear up the streets!

COMPLETE BASE KIT STARTING AT \$5,092

COMPLETE BASE KIT

Description	Part#	Base Price
62-67 Nova	NVF-320	5,092.00

CONTROL ARM OPTIONS

Description	Part#	Add
Plain Control Arms	CF-102	Included
Plain Control Arms 8° Addl. Positive Caster (optional)	CF-102-8-H	Included
Polished Stainless Steel Control Arms	CF-103	\$1,879.00

SPINDLE OPTIONS

Description	Part#	Add
2" Dropped Spindles	SP-110	Included

BRAKE OPTIONS

Description	Part#	Add
11" Wilwood Rotors & 4 Piston Black Calipers	DF-221-B	Included
12" Wilwood Drilled Rotors & 4 Piston Black, Polished Calipers	DF-222-D-B	465.00
13" Wilwood Drilled Rotors & 6 Piston Black, Polished Calipers	DF-223-D-B	1,685.00

Additional options available. Call for pricing.

RACK & PINION OPTIONS

Description	Part#	Add
Power Rack with 17mm "DD" Input Shaft	OPR-1-D-K	Included

SHOCK & SPRING OPTIONS

Description	Part#	Add
Plain Billet Coil-Over Shocks	CB-160-K	Included
400#, 450#, 500#, 550# Silver Powder Coated Springs	CS-XXX-10	Included
Thrust Bearings For Coil-Over Shocks	CQ-010	40.00
Spanner Wrench	TA-001	18.00

ADDITIONAL OPTIONS

Description	Part#	Price
62-65 Nova Steel Inner Fender Panels	CX-327	470.00
66-67 Nova Steel Inner Fender Panels	CX-328	470.00
62-67 Nova Swaybar 1 1/4 Spline	SB-403	702.00
Steering Hookup Kit	SC-307	342.00



DF-222-D-P

DF-223-D-B

SP-110

TA-001

CB-160

CX-327



'62-'67 NOVA

4-LINK KIT FOR NOVA REAR



Owner/Builder:
Bill Jelinek
Route 66 Motorsports

INCLUDED IN BASE KIT:

- 4-Link Chassis and Axle Brackets •
- Top Crossmember • Panhard Bar •
- Subframe Connectors • Standard Black Coil-Over Shocks and Black Springs

Now with Silver Powder Coated Springs! Powder coating does not rust or peel while saving you money!

**COMPLETE BASE KIT
STARTING AT \$1,507**

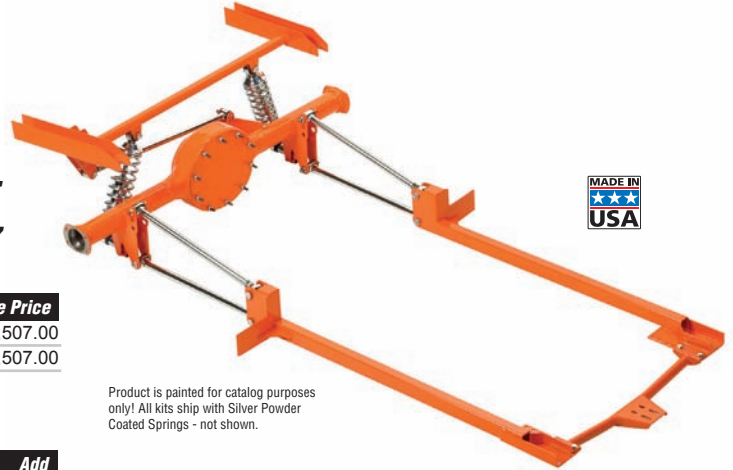

Product is painted for catalog purposes only! All kits ship with Silver Powder Coated Springs - not shown.

COMPLETE BASE KIT

Description	Part#	Base Price
62-67 Nova Weld-In	RN-101	1,507.00
62-67 Nova Bolt-In	RN-101-B	1,507.00

SHOCK & SPRING OPTIONS

Description	Part#	Add
Black Coil-Over Shocks	CO-101	Included
250#, 300#, 350# Black Coil Springs	CR-XXX-11-B	Included
Billet Coil-Over Shocks/Silver Powder Coated Springs	CB-105-K	173.00
250#, 300#, 350# Silver Powder Coated Springs w/CB-105	CR-XXX-11-C	Included

LINKS & PANHARD BAR OPTIONS

Description	Part#	Add
Plain 4 Links and Bar Kit	RN-051	Included
Polished Stainless Steel 4 Links and Bar Kit	RN-052	1,042.00



RN-052

SUBFRAME CONNECTORS

Description	Part#	Included
Subframe Connectors	RN-050	Included

AXLE HOUSING AND AXLE OPTIONS

Description	Part#	Price
Housing With Brackets Installed	RN-013-55-H	809.00
31 Spline Axles - Chevy Bolt Pattern - 55" Track Width	RN-014-55-31	653.00
31 Spline Axles - Ford Bolt Pattern - 55" Track Width	RN-014-55-31-F	653.00

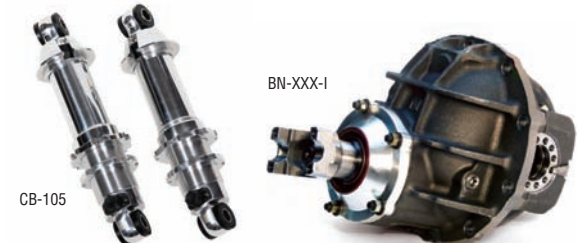

CB-105

BN-XXX-I

3RD MEMBER OPTIONS

Description	Part#	Price
Open 31 Spline 3.00, 3.25, 3.50, 3.70, 3.90, 4.11 Ratio	BN-XXX-I	766.00
Positraction 31 Spline 3.00, 3.25, 3.50, 3.70, 3.90, 4.11 Ratio	BN-XXX-I-L	1,296.00



RN-014-55-31

BRAKE OPTIONS

Description	Part#	Price
11" Heavy Duty Drum Brake	RN-054	630.00
12" Iron Rotors, GM Single Piston Calipers W/Parking Brake	DR-005-E-P	753.00
12" Wilwood Smooth Rotors & 4 Piston Black Calipers W/Parking Brake	DR-005-P-B	766.00
12" Wilwood Smooth Rotors & 4 Piston Red Calipers W/Parking Brake	DR-005-P-RED	861.00
12" Wilwood Smooth Rotors & 4 Piston Polished Calipers W/Parking Brake	DR-005-P	842.00
12" Wilwood Drilled Rotors & 4 Piston Black Calipers W/Parking Brake	DR-005-P-D-B	845.00
12" Wilwood Drilled Rotors & 4 Piston Red Calipers W/Parking Brake	DR-005-P-D-RED	945.00
12" Wilwood Drilled Rotors & 4 Piston Polished Calipers W/Parking Brake	DR-005-P-D	958.00



RN-054

DR-XXX-P

RN-053

ADDITIONAL OPTIONS

Description	Part#	Price
62-67 Nova Trans Crossmember	RN-053	84.00
62-67 Nova Drive Shaft Hoop	RN-057	130.00
62-67 Nova Rear Swaybar (For Use With HEIDTS® 4-Link Kit Only)	SB-130	204.00



Order/Tech: 800-841-8188

HEIDTS®
SUSPENSION SYSTEMS

HEIDTS® MUSCLE CAR PARTS

'62-'67 NOVA

HEIDTS PRO-G IRS



Now with Silver Powder Coated Springs! Powder coating does not rust or peel while saving you money!

HIGH HORSEPOWER INDEPENDENT REAR SUSPENSION

WHY HEIDTS PRO-G® IRS



Do you really want to go fast and out-handle everyone else on the autocross or road race course in your Nova? Full independent rear suspension is the only way to go. HEIDTS® now has a High Horsepower Independent Rear Suspension bolt-In Package that will do the job just fine.

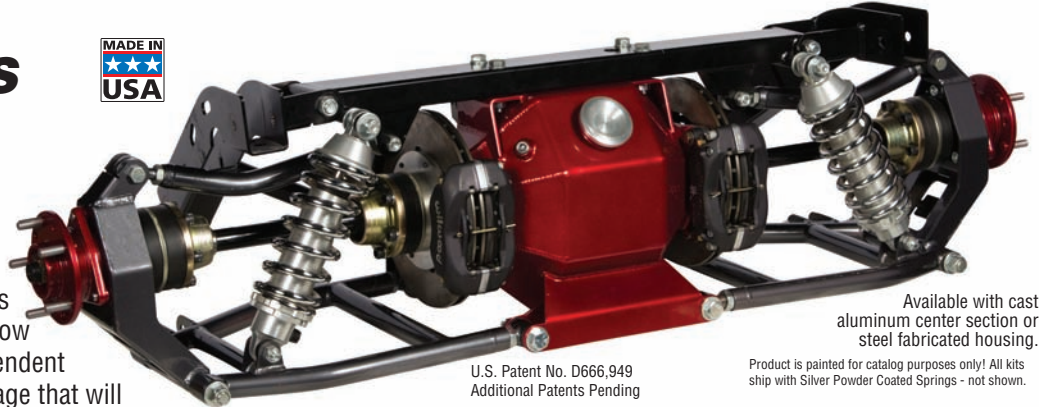

U.S. Patent No. D666,949
Additional Patents Pending

Available with cast aluminum center section or steel fabricated housing.
Product is painted for catalog purposes only! All kits ship with Silver Powder Coated Springs - not shown.

COMPLETE BASE KIT STARTING AT \$9,320

It is a true high horsepower package, with upper links and heavy duty CV joints. The upper link produces $-.5^\circ$ of camber curve at 3/4 of total travel, during very high cornering loads. Forward struts, attached to the sub-frame connectors insures the wheels stay in place during hard acceleration.



*Subframe Connectors Included.



WHAT YOU GET:

- Track Width 56 1/2"
- 9" Aluminum HSG.
- 3rd Member, Iron, Posi
- CV Joint Halfshafts
- Tubular Upper & Lower Arms
- Steel Outer Uprights
- Top Crossmember
- Frame Mounting Brackets
- Front Pinion Support
- Forward Struts*
- 10.5" Wilwood Rotors
- Black Wilwood Calipers
- Billet Single Adjustable Coil-Overs with Silver Powder Coated Springs
- Posi-Traction

OPTIONS: CALL FOR DETAILS.

- Choice of Gear Ratios
- Parking Brake Kit and Cable Kit

"About once every ten years, someone comes up with a breakthrough part in the aftermarket. The HEIDTS® Bolt-in Independent Rear suspension could be that part for 2011 and beyond"

Quoted from Jim Campisano - Editor Super Chevy Magazine, January Issue



COMPLETE BASE KIT

Description	Part#	Base Price
62-67 Nova High Horsepower IRS - Plain Rotors	NVR-101	9,320.00
62-67 Nova High Horsepower IRS - Drilled & Slotted Rotors	NVR-101-S	9,654.00

SHOCK & SPRING OPTIONS

Description	Part#	Add
Plain Billet Coil-Over Shocks	CB-106	Included
350# Silver Powder Coated Springs w/CB-106	CR-350-11-C	Included
400# Silver Powder Coated Springs w/CB-106	CR-400-11-C	Included
450# Silver Powder Coated Springs w/CB-106	CR-450-11-C	Included
550# Silver Powder Coated Springs w/CB-106	CR-450-11-C	Included

3RD MEMBER OPTIONS

Description	Part#	Price
Positraction 31 Spline 3.00 Ratio	BN-300-I-L	Included
Positraction 31 Spline 3.25 Ratio	BN-325-I-L	Included
Positraction 31 Spline 3.50 Ratio	BN-350-I-L	Included
Positraction 31 Spline 3.70 Ratio	BN-370-I-L	Included
Positraction 31 Spline 3.90 Ratio	BN-390-I-L	Included
Positraction 31 Spline 4.11 Ratio	BN-411-I-L	Included

SUBFRAME CONNECTOR

Description	Part#	Price
62-67 Nova Subframe Connectors - Coupe	NVR-140	Included

PARKING BRAKE OPTIONS

Description	Part#	Price
Parking Brake Kit & Cable Kit	PB-101	589.00
E-Stop Actuator	BM-013	699.00

HOUSING OPTIONS

Description	Part#	Add
Polished Aluminum 9" Housing	BM-001-P	205.00
Steel Fab 9" Housing	BT-410	

'68-'74 NOVA FRONT SUBFRAME WIDE TIRE SERIES

Builder:
Performance
Restorations



INCLUDED IN BASE KIT:

- HEIDTS PRO-G® Subframe
- HEIDTS PRO-G® 2" Dropped Spindles
- Transmission X-Member
- Tubular Upper & Lower Arms
- Power Rack & Pinion Steering
- 11" Wilwood Brakes with Black Calipers
- Billet Coil-Overs, Single Adjustable Shocks with Silver Powder Coated Springs



Now with Silver Powder Coated Springs! Powder coating does not rust or peel while saving you money!

COMPLETE SUBFRAME BASE KIT

Description	Part#	Base Price
68-74 Nova (Includes Trans Crossmember)	CF-101-WT	5,092.00

CONTROL ARM OPTIONS

Description	Part#	Add
Plain Control Arms	CF-102	Included
Plain Control Arms 8" Addl. Positive Caster (optional)	CF-102-8-H	Included
Polished Stainless Steel Control Arms	CF-103	\$1,879.00

BRAKE OPTIONS

Description	Part#	Add
11" Wilwood Smooth Rotors & 4 Piston Black Calipers	DF-221-B	Included
12" Wilwood Drilled Rotors & 4 Piston Black Calipers	DF-222-D-B	465.00
13" Wilwood Drilled Rotors & 6 Piston Black Calipers	DF-223-D-B	1,685.00

Additional options available. Call for pricing.

SPINDLE OPTION

Description	Part#	Add
2" Dropped Spindles	SP-110	Included

POWER RACK & PINION OPTIONS

Description	Part#	Add
Power Rack	MP-038-3-K	Included
Power Rack W/ Stainless Steel Tie Rod Ends	MP-038-SS-K	135.00

SHOCK & SPRING OPTIONS

Description	Part#	Add
Plain Billet Coil-Over Shocks	CB-160	Included
400#, 450#, 500#, 550#, 600#, 700# Silver Powder Coated 10" Springs	CS-XXX-10	Included
Thrust Bearings For Coil Over Shocks	CQ-010	40.00
Spanner Wrench	TA-001	18.00

ADDITIONAL OPTIONS

Description	Part#	Price
Upper Arm "Heim Style" Adjuster Kit	CF-104	213.00
68-72 Nova Pre Bent Brake Line Kit	CF-111	86.00
Steering Hookup Kit For Power Rack DD	SC-298	291.00
1" Swaybar	SB-110	281.00
1-1/4" Swaybar	SB-111	346.00
1-1/4" Splined Swaybar	SB-401	702.00
68-74 Nova Subframe Connectors	RN-056-WT	224.00
68-74 Nova Drive Shaft Hoop (Subframe Connectors Required)	RC-037	96.00
Body Mount Kit Urethane Bushings	CF-106	106.00
Body Mount Kit Aluminum Bushings	CF-109	244.00
Motor Mount Stands	MM-220	Included

HEIDTS® now offers their bolt on front subframe. Featuring their new HEIDTS Pro-G® suspension package for unbelievable cornering and overall handling. Simply unbolt and remove your front sheetmetal, engine/trans, old subframe, then slide in the new complete HEIDTS® Subframe. Reinstall your engine/trans and sheetmetal. HEIDTS® makes high end handling affordable!

BOLT A "PRO-G™" ON YOUR CAR



'70-'81 CAMARO SHOWN. Product is painted for catalog purposes only!

PACKAGES SHIP UNASSEMBLED VIA TRUCK FRIEGHT.



Product is painted for catalog purposes only! All kits ship with Silver Powder Coated Springs - not shown. *Airbags will not fit.

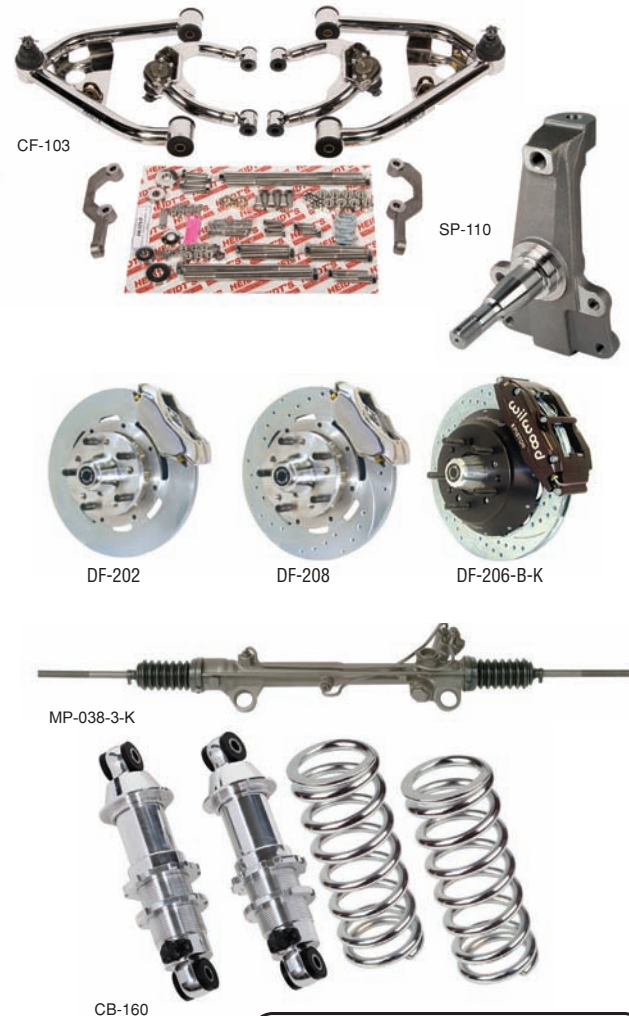

Order/Tech: 800-841-8188



HEIDTS® MUSCLE CAR PARTS

'68-'72 NOVA

HEIDTS PRO G 4-LINK KIT FOR NOVA REAR

Bolt-on maximum performance for your Nova. Kit includes chassis and axle brackets, adjustable links, full upper coil-over crossmember, panhard bar, adjustable HEIDTS® coil-overs and all hardware. Completely bolt-on, with no cutting or floor modifications. Adjustable 4-link mounts allow suspension tuning.

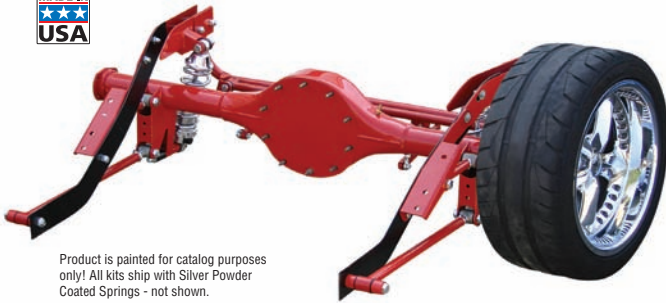

Product is painted for catalog purposes only! All kits ship with Silver Powder Coated Springs - not shown.



RC-107



CO-101
CR-XXX-11-B



RC-041-60-31



BN-XXX-I



RN-054



DR-005-P



RC-037

Builder:
Performance
Restorations



PACKAGES SHIP UNASSEMBLED
VIA TRUCK FRIEGHT.

Now with Silver Powder Coated Springs! Powder coating does not rust or peel while saving you money!

INCLUDED IN BASE KIT:

- 4-Links with Spherical Bearings and Axle Brackets
- Top Crossmember
- Panhard Bar
- Standard Coil-Over Shocks, Black Body and Black Springs

COMPLETE 4-LINK BASE KIT

Description	Part#	Base Price
68-72 Nova	RC-131-WT	\$1,507.00
68-72 Nova (Use If Ordering 9" Housing)	RC-131-WT-H	\$1,507.00

LINKS & PANHARD BAR OPTIONS

Description	Part#	Add
Plain Links and Panhard Bar	RC-106	Included
Polished Stainless Steel Links and Panhard Bar	RC-107	\$747.00

SHOCK & SPRING OPTIONS

Description	Part#	Add
Black Coil-Over Shocks	CO-101	Included
250#, 300#, 350# Black Coil Springs	CR-XXX-11-B	Included
Billet Coil-Over Shocks/Silver Powder Coated Springs	CB-105	173.00
250#, 300#, 350# Silver Powder Coated Springs	CR-XXX-11-C	Included
Thrust Bearings For Coil-Over Shocks	CQ-010	40.00
Spanner Wrench	TA-001	18.00

AXLE HOUSING AND AXLE OPTIONS

Description	Part#	Price
60" Track Width Housing With Brackets Installed	RC-040-60-H-WT	809.00
60" Track Width 31 Spline Axles with Chevy Bolt Pattern	RC-041-60-31	653.00

3RD MEMBER OPTIONS

Description	Part#	Add
Open 31 Spline 3, 3.25, 3.50, 3.70, 3.90, 4.11 Ratio	BN-XXX-I	766.00
Positraction 31 Spline 3, 3.25, 3.50, 3.70, 3.90, 4.11 Ratio	BN-XXX-I-L	1,296.00

BRAKE OPTIONS

Description	Part#	Price
11" Heavy Duty Drum Brake	RN-054	630.00
12" Iron Rotors, GM Single Piston Calipers W/Parking Brake	DR-005-E-P	753.00
12" Wilwood Smooth Rotors & 4 Piston Black Calipers W/Parking Brake	DR-005-P-B	766.00
12" Wilwood Smooth Rotors & 4 Piston Red Calipers W/Parking Brake	DR-005-P-RED	861.00
12" Wilwood Smooth Rotors & 4 Piston Polished Calipers W/Parking Brake	DR-005-P	842.00
12" Wilwood Drilled Rotors & 4 Piston Black Calipers W/Parking Brake	DR-005-P-D-B	845.00
12" Wilwood Drilled Rotors & 4 Piston Red Calipers W/Parking Brake	DR-005-P-D-RED	945.00
12" Wilwood Drilled Rotors & 4 Piston Polished Calipers W/Parking Brake	DR-005-P-D	958.00

SUBFRAME CONNECTOR OPTIONS

Description	Part#	Price
68-72 Nova Subframe Connectors - Factory Subframe	RN-055	215.00
68-72 Nova Subframe Connectors (Use with Pro-G)	RN-056-WT	215.00

ADDITIONAL OPTIONS

Description	Part#	Add
Rear Sway Bar	SB-009	286.00
Drive Shaft Hoop	RC-037	96.00

'55-'57 CHEVY



TUBULAR UPPER & LOWER CONTROL ARMS

Description	Part#	Price
UPPER		
Plain Control Arms	CA-201	449.00
Plain Control Arms With 6 Degrees of Additional Caster	CA-201-6	449.00
Polished Stainless Steel Control Arms	CA-201-SS	863.00
Polished Stainless Steel Control Arms With 6 Degrees of Additional Caster	CA-201-SS-6	863.00

LOWER		
*Plain Control Arms, Standard Shocks and Springs	CA-203	783.00
*Plain Control Arms For Coil-Over Shocks	CA-203-M	783.00
*Polished Stainless Steel Control Arms	CA-203-SS	1,566.00
*Polished Stainless Steel Control Arms For Coil-Over Shocks	CA-203-SS-M	1,566.00

*Control Arm work with HEIDTS Spindle Only. Must use Coil Overs with Narrow Arms.
Control Arms can be shipped unassembled for powdercoat painting.



BUSHING & BALL JOINT CAPS

Upper & Lower Control Arm Bushing Caps. Fully polished aluminum, with polished stainless bolts, will fit Tubular Control Arms or stock control arms.

The finishing touch to your suspension. Cover those upper ball joints with our Ball Joint Caps. They are polished stainless steel, including polished screws.

Description	Part#	Price
Stainless Steel Ball Joint Caps (1 Pair)	CA-210	81.00
Polished Aluminum Bushing Caps (Complete Set)	CA-211	195.00

Note: CA-211 is a set of 8 caps!

COIL-OVERS & 1" DROPPED COIL SPRINGS

HEIDTS® Billet aluminum coil-over shocks are fully adjustable for ride height and dampening. Specifically designed full length conical springs are powder coated bright silver. Two progressive spring rates for big blocks or small blocks. Fits coil-over arms or stock applications.

To give your 'Shoobox' an even lower look, add these HEIDTS® 1" Dropped Coil Springs. They are 1" shorter than New factory springs. Combined with our 2" Dropped Spindles, they will put your cruiser a full 3" in the weeds safely and easily.

Description	Part#	Price
55-57 Chevy Coil-Over Shocks	CB-120	400.00
450# 11" Silver Powder Coat Coil-Over Springs - Small Block	CQ-450-11	162.00
550# 11" Silver Powder Coat Coil-Over Springs - Big Block	CQ-550-11	162.00
1" Dropped Coil Springs (Factory Style) - Small Block	CS-060	107.00
Thrust Bearings For Coil-Over Shocks	CQ-010	40.00
Spanner Wrench	TA-001	18.00

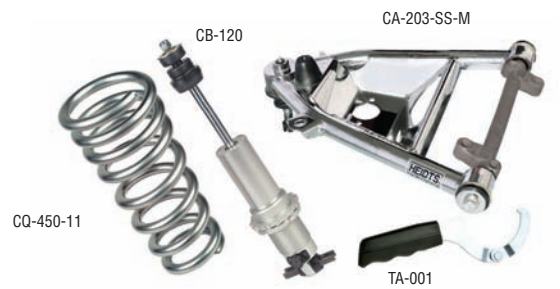

STABILIZER BAR KITS

Stabilizer bars, or sway bars, are used to control body roll and sway. HEIDTS® Stabilizer Bars for '55-'57 Chevys are made of heat treated steel. They are available in either 7/8" or 1" bar, with urethane bushings.

Description	Part#	Price
7/8" Front Swaybar With Urethane Bushings	SB-050-U	200.00
1" Front Swaybar With Urethane Bushings	SB-051-U	200.00
7/8" Rear Swaybar With Urethane Bushings	SB-052	195.00



'55-'57 CHEVY

HEIDTS® front suspension components are perfect for lowering, stopping and just flat out making your Tri-Five handle. With our components you will get the look, the stopping power and the handling you deserve.

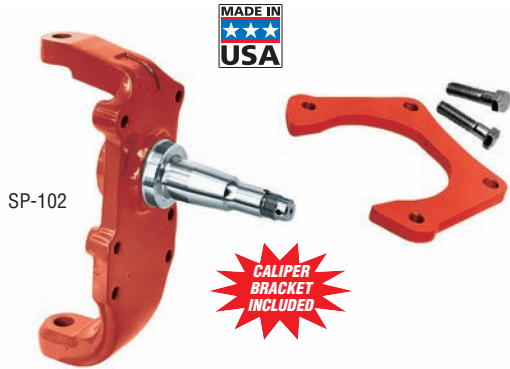

HEIDTS 2" DROPPED STEEL SPINDLE

Our 2" Dropped Spindles are full steel spindles, just like factory spindles. This is much stronger than cast iron. They use your stock steering arms, with no loss of turning radius. No realignment required. The caliper brackets bolt on like mid-70's Chevys, allowing many brake options shown.

Description	Part#	Price
2" Dropped Spindles - Late GM Brackets	SP-102	388.00
2" Dropped Spindles (69-72 Calipers) - Early GM Brackets	SP-102-B	399.00
2" Dropped Spindles - Use with Wilwood Brake Kits (Pair)	SP-002-A	184.00

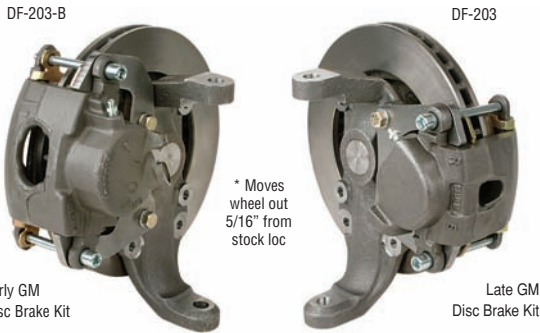

* Moves wheel out 5/16" from stock loc

DISC BRAKE KITS

All the components needed to complete your 2" Dropped Spindle installation for either Late GM or Early GM calipers. Includes rotors, Calipers with Pads, Bearings and Seals, Spindle Nuts, Dust Caps, Hoses and Banjo Bolts. The "Conversion Kit" updates early stock spindle disc brake kits to our 2" spindles. Spindles not included.

Description	Part#	Price
10.5" Rotors, B-Body Single Piston Calipers for HEIDTS® Spindle	DF-203	341.00
10.5" Rotors, A-Body Single Piston Calipers for HEIDTS® Spindle	DF-203-B	341.00
11" Rotors, A-Body Single Piston Calipers for Stock Spindle	DF-204	323.00
11" Wilwood Rotors, 4 Piston Polished Calipers & Hardware*	DF-205	918.00
11" Wilwood Drilled Rotors W/ Polished Hubs, 4 Piston Polished Calipers & Hardware*	DF-205-D	1,097.00
12" Wilwood Drilled Rotors W/ Polished Hubs, 4 Piston Polished Calipers & Hardware*	DF-210-D	1,128.00
13" Wilwood Drilled Rotors W/ Black Hubs, 4 Piston Black Calipers & Hardware*	DF-211-D	2,062.00

*For Heidts® 2" Dropped Spindles



* Moves wheel out 7/16" from stock location

MISC. BRAKE PARTS

Description	Part#	Price
10.5" Chevelle Rotors (79-81)	DF-019	135.00
11" Chevelle Rotors (69-72)	DF-046	130.00
Chevelle Caliper Set (78-84)	DF-009	125.00
Caliper Bracket Kit For Stock Spindles	DF-104	125.00
11" Caliper Bracket Kit For Wilwood Calipers	DF-105	81.00
12" Caliper Bracket Kit For Wilwood Calipers	DF-106	89.00

'55-'57 CHEVY TRIANGULAR 4-LINK

HEIDTS® '55-'57 Chevy Triangulated 4-Link Kit is a very popular kit as it does not require a Panhard Rod. Bars are fully adjustable, 1-1/4" X .156 tube with 3/4" stainless adjusters and urethane bushings, angled and straight chassis brackets, tabs and hardware.

These kits are available in plain steel or polished stainless steel tubes.
NOTE: Intended for stock or aftermarket frames.

INCLUDED IN BASE KIT:

- 4-Link Chassis and Axle Brackets
- Top Crossmember
- Standard Black Coil-Over Shocks and Black Springs

Now with Silver Powder Coated Springs! Powder coating does not rust or peel while saving you money!

**COMPLETE BASE KIT
STARTING AT \$1,507**

COMPLETE BASE KIT

Description	Part#	Base Price
55-57 Chevy	RC-151	1,507.00
55-57 Chevy (Use if Ordering 9" Housing)	RC-151-H	1,507.00

LINKS & PANHARD BAR OPTIONS

Description	Part#	Add
Plain 4 Links and Bar Kit	RC-152	Included
Polished Stainless Steel 4 Links and Bar Kit	RC-153	632.00

SHOCK & SPRING OPTIONS

Description	Part#	Add
Black Coil-Over Shocks	CO-101	Included
250#, 300#, 350# Black Coil Springs	CR-XXX-11-B	Included
Billet Coil-Over Shocks/Silver Powder Coated Springs	CB-105	173.00
250#, 300#, 350# Silver Powder Coated Coil Springs	CR-XXX-11-C	Included

AXLE HOUSING AND AXLE OPTIONS

Description	Part#	Price
Housing With Brackets Installed - 58" Track Width	RC-140-58-H	809.00
Housing With Brackets Installed - 60" Track Width	RC-140-60-H	809.00
55" Track Width 31 Spline Axle with Chevy Bolt Pattern	RC-041-55-31	653.00
56" Track Width 31 Spline Axle with Chevy Bolt Pattern	RC-041-56-31	653.00
58" Track Width 31 Spline Axle with Chevy Bolt Pattern	RC-041-58-31	653.00
59" Track Width 31 Spline Axle with Chevy Bolt Pattern	RC-041-59-31	653.00
60" Track Width 31 Spline Axle with Chevy Bolt Pattern	RC-041-60-31	653.00

3RD MEMBER OPTIONS

Description	Part#	Price
Open 31 Spline 3.00, 3.25, 3.50, 3.70, 3.90, 4.11 Ratio	BN-XXX-I	766.00
Positraction 31 Spline 3.00, 3.25, 3.50, 3.70, 3.90, 4.11 Ratio	BN-XXX-I-L	1,296.00

BRAKE OPTIONS

Description	Part#	Price
11" Heavy Duty Drum Brake	RN-054	630.00
12" Iron Rotors, GM Single Piston Calipers W/Parking Brake	DR-005-E-P	753.00
12" Wilwood Smooth Rotors & 4 Piston Black Calipers W/Parking Brake	DR-005-P-B	766.00
12" Wilwood Smooth Rotors & 4 Piston Red Calipers W/Parking Brake	DR-005-P-RED	861.00
12" Wilwood Smooth Rotors & 4 Piston Polished Calipers W/Parking Brake	DR-005-P	842.00
12" Wilwood Drilled Rotors & 4 Piston Black Calipers W/Parking Brake	DR-005-P-D-B	845.00
12" Wilwood Drilled Rotors & 4 Piston Red Calipers W/Parking Brake	DR-005-P-D-RED	945.00
12" Wilwood Drilled Rotors & 4 Piston Polished Calipers W/Parking Brake	DR-005-P-D	958.00

SWAYBAR OPTIONS

Description	Part#	Price
Plain Swaybar	SB-180	179.00
Chrome Swaybar	SB-180-C	443.00



MUST USE FORD 9" HOUSING



Shown with options. Product is painted for catalog purposes only!



RC-140-60-H



BN-XXX-I

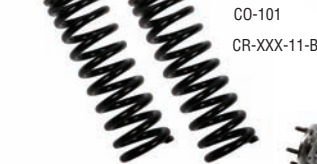

CO-101

CR-XXX-11-B



RC-041-60-31



RN-054

DR-005-P



Order/Tech: 800-841-8188

'55-'57 CHEVY

HEIDTS PRO-G IRS



BOLT-IN INDEPENDENT REAR SUSPENSION

Patent Pending

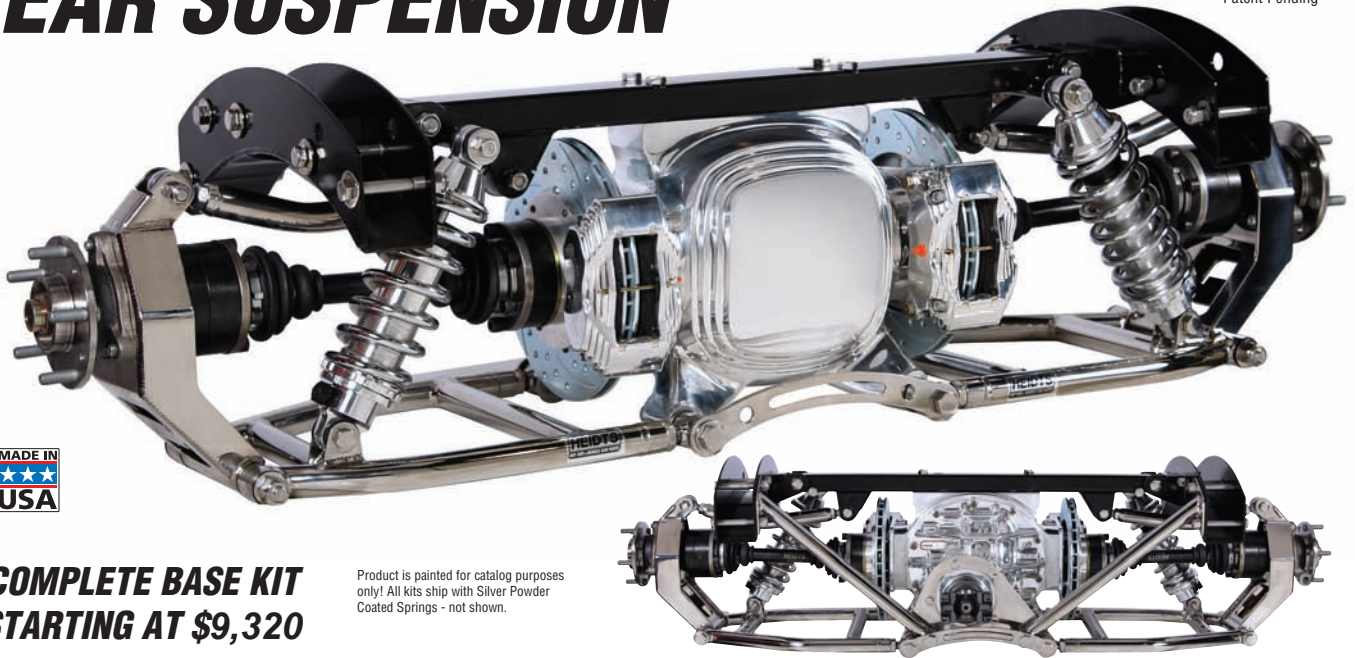

**COMPLETE BASE KIT
STARTING AT \$9,320**

Product is painted for catalog purposes only! All kits ship with Silver Powder Coated Springs - not shown.

The Tri-Five **HEIDTS Pro-G**® IRS is a true bolt-in, high horsepower Independent Rear Suspension System for 1955 through 1957 Chevy cars. This industry-leading design is based off the proven and award-winning **HEIDTS Pro-G**® IRS geometry, while the bolt-in design means it can be installed on cars that are already complete or easily added to builds already underway. The Tri-Five **HEIDTS Pro-G**® IRS also features several design enhancements to make exhaust routing easier.

INCLUDED IN BASE KIT:

- Top Crossmembers • Upper & Lower Arms
- Aluminum Uprights • CV Joint Halfshafts
- 9" Aluminum Housing • 3rd Member, Iron, Posi
- 10.5" Wilwood Rotors with 4 Piston Polished Calipers
- Billet Single Adjustable Coil-Over Shocks with Silver Powder Coated Springs

Now with Silver Powder Coated Springs! Powder coating does not rust or peel while saving you money!

Also available in fully polished version as shown. Call for details.

COMPLETE BASE KIT

Description	Part#	Base Price
55-57 CHEVY High Horsepower IRS - Plain Rotors	IRS-151	9,320.00
55-57 CHEVY High Horsepower IRS - Drilled Rotors	IRS-151-S	9,655.00
55-57 CHEVY High Horsepower IRS - Polished Pkg. - Smooth Rotors	IRS-151-P	15,325.00
55-57 CHEVY High Horsepower IRS - Polished Pkg. - Drilled Rotors	IRS-151-S-P	15,660.00

SHOCK & SPRING OPTIONS

Description	Part#	Add
Plain Billet Coil-Over Shocks	CB-106	Included
350# Silver Powder Coated Springs w/CB-106	CR-350-11-C	Included
400# Silver Powder Coated Springs w/CB-106	CR-400-11-C	Included
450# Silver Powder Coated Springs w/CB-106	CR-450-11-C	Included
550# Silver Powder Coated Springs w/CB-106	CR-450-11-C	Included

3RD MEMBER OPTIONS

Description	Part#	Price
Positraction 31 Spline 3.00 Ratio	BN-300-I-L	Included
Positraction 31 Spline 3.25 Ratio	BN-325-I-L	Included
Positraction 31 Spline 3.50 Ratio	BN-350-I-L	Included
Positraction 31 Spline 3.70 Ratio	BN-370-I-L	Included
Positraction 31 Spline 3.90 Ratio	BN-390-I-L	Included
Positraction 31 Spline 4.11 Ratio	BN-411-I-L	Included

HOUSING OPTIONS

Description	Part#	Add
Polished Aluminum 9" Housing	BM-001-P	205.00
Steel Fab 9" Housing	BT-410	

HEIDTS PRO-G[®] IRS

UNIVERSAL HIGH HORSEPOWER INDEPENDENT REAR SUSPENSION

WHY HEIDTS PRO-G[®] IRS

HEIDTS[®] now has a High Horsepower Independent Rear Suspension bolt-In Package for almost any car. For those of you who want ultra modern handling in your classic car can now have it with this fully independent suspension. This full independent rear suspension is the only way to go.

It is a true high horsepower package, with upper links and heavy duty CV joints. The upper link produces $-.5^{\circ}$ of camber curve at 3/4 of total travel, especially during very high cornering loads. Forward struts, attached to the sub-frame connectors insures the wheels stay in place during hard acceleration.



U.S. Patent No. D666,949
Additional Patents Pending

Product is painted for catalog purposes only! All kits ship with Silver Powder Coated Springs - not shown.

COMPLETE BASE KIT STARTING AT \$9,114

Now with Silver Powder Coated Springs! Powder coating does not rust or peel while saving you money!

COMPLETE BASE KIT

Description	Part#	Base Price
Universal High Horsepower IRS - Plain Rotors	IRU-56	9,114.00
Universal High Horsepower IRS - Drilled & Slotted Rotors	IRU-58	9,114.00

SHOCK & SPRING OPTIONS

Description	Part#	Add
Plain Billet Coil-Over Shocks	CB-106	Included
350# Silver Powder Coated Springs w/CB-106	CR-350-11-C	Included
400# Silver Powder Coated Springs w/CB-106	CR-400-11-C	Included
450# Silver Powder Coated Springs w/CB-106	CR-450-11-C	Included
550# Silver Powder Coated Springs w/CB-106	CR-450-11-C	Included

3RD MEMBER OPTIONS

Description	Part#	Price
Positraction 31 Spline 3.00 Ratio	BN-300-I-L	Included
Positraction 31 Spline 3.25 Ratio	BN-325-I-L	Included
Positraction 31 Spline 3.50 Ratio	BN-350-I-L	Included
Positraction 31 Spline 3.70 Ratio	BN-370-I-L	Included
Positraction 31 Spline 3.90 Ratio	BN-390-I-L	Included
Positraction 31 Spline 4.11 Ratio	BN-411-I-L	Included

PARKING BRAKE OPTIONS

Description	Part#	Price
Parking Brake Kit & Cable Kit - Black	PB-101	589.00
Parking Brake Kit & Cable Kit - Silver	PB-101-S	589.00
E-Stop Actuator	BM-013	699.00

HOUSING OPTIONS

Description	Part#	Add
Polished Aluminum 9" Housing	BM-001-P	205.00
Steel Fab 9" Housing	BT-410	

WHAT YOU GET:

- Track Width 56 1/2" or 58 1/2"
- 9" Aluminum HSG.
- 3rd Member, Iron, Posi
- CV Joint Halfshafts
- Tubular Upper & Lower Arms
- Steel Outer Uprights
- Top Crossmember
- Frame Mounting
- Brackets
- Front Pinion Support
- Forward Struts*
- 10.5" Wilwood Rotors
- Black Wilwood Calipers
- Billet Single Adjustable Coil-Overs with Silver Powder Coated Springs
- Posi-Traction
- Step-By-Step Instructions

OPTIONS: CALL FOR DETAILS.

- Choice of Gear Ratios
- Parking Brake Kit and Cable Kit



"About once every ten years, someone comes up with a breakthrough part in the aftermarket. The HEIDTS[®] Bolt-in Independent Rear Suspension could be that part for 2011 and beyond"

Quoted from Jim Campisano - Editor Super Chevy Magazine, January Issue



Order/Tech: 800-841-8188

HEIDTS[®] MUSCLE CAR PARTS

RIGHT HAND DRIVE MUSCLE CAR SUSPENSION KITS



DRIVE RIGHT - DRIVE HEIDTS!



HEIDTS® Right Hand Suspension Systems will give your Muscle Car the ride, handling and stopping power you are after (Comes standard with dropped spindles). Assembled package is shown so you can see what your completed front end will look like.

Now with Silver Powder Coated Springs! Powder coating does not rust or peel while saving you money!



CF-101-WT-RH

67-81 CAMARO PRO-G RIGHT HAND DRIVE, POWER ONLY

Description	Part#	Price
67-69 Camaro	CF-101-WT-RH	5,215.00
70-81 Camaro	CF-201-WT-RH	5,215.00

Product is painted for catalog purposes only! All kits ship with Silver Powder Coated Springs - not shown.



CX-320-S-K-RH

62-73 NOVA RIGHT HAND DRIVE FRONT SUBFRAMES, POWER ONLY

Description	Part#	Price
62-67 Nova Mustang II RH	CX-320-S-K-RH	3,150.00
62-67 Nova Superide II RH	BX-320-RH	4,015.00
62-67 Nova Pro-G RH	NVF-320-RH	5,215.00
68-73 Nova Pro-G RH	CF-101-WT-RH	5,215.00

Product is painted for catalog purposes only! All kits ship with Silver Powder Coated Springs - not shown.



MTF-101-RH

64-1/2 - 70 MUSTANG RIGHT HAND DRIVE POWER ONLY

Description	Part#	Price
64-1/2 - 70 Mustang, Mustang II	PX-320-E-K-RH	2,745.00
64-1/2 - 70 Mustang Superide II	BX-340-RH	3,699.00
64-1/2 - 70 Mustang Pro-G	MTF-101-RH	5,215.00

Product is painted for catalog purposes only! All kits ship with Silver Powder Coated Springs - not shown.

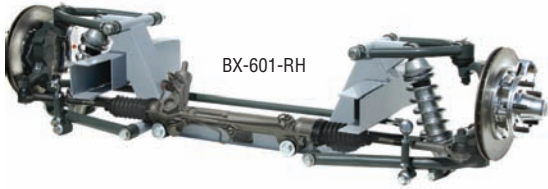

BX-601-RH

FALCON, COMET, AND FAIRLANE RIGHT HAND DRIVE, POWER ONLY

Description	Part#	Price
62-65 Falcon Mustang II	PX-330-E-K	2,745.00
66-67 Fairlane/Comet Superide II	BX-601-RH	3,810.00

Product is painted for catalog purposes only! All kits ship with Silver Powder Coated Springs - not shown.

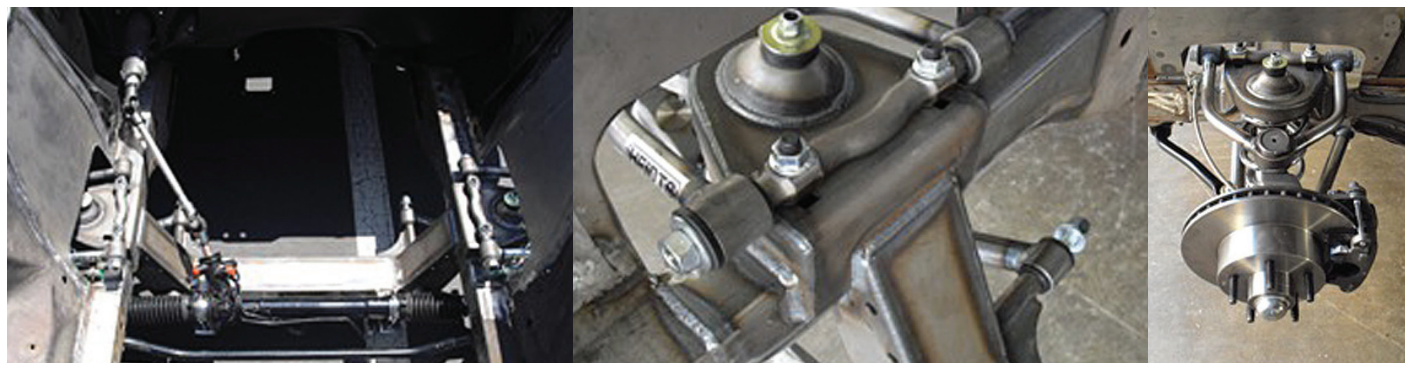

RIGHT HAND DRIVE STREET ROD SUSPENSION KITS



INCLUDED IN BASE KITS:

- HEIDTS® Crossmember
- Tubular Upper & Lower Arms
- Stock Mustang II Spindles
- Manual Rack & Pinion Steering
- 11" Rotors with 4 Piston Wilwood Calipers
- Billet Single Adjustable Coil-Over Shocks with Silver Powder Coated Springs

Now with Silver Powder Coated Springs! Powder coating does not rust or peel while saving you money!



SUPERIDE RIGHT HAND DRIVE REAR STEER MANUAL ONLY

Description	Part#	Price
Superide Openwheel for pinched rails	BX-105-RH	4,136.00
28-31 Ford Superide	BX-101-RH	3,671.00
32 Ford Superide	BX-102-RH	3,671.00
33-34 Ford Superide	BX-103-RH	3,671.00
28-35 Chevy Superide	BX-114-RH	3,671.00

Product is painted for catalog purposes only! All kits ship with Silver Powder Coated Springs - not shown.

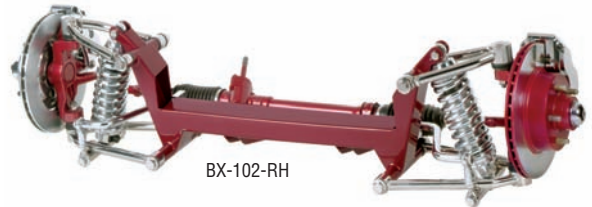

BX-102-RH

STREET ROD SUPERIDE II RIGHT HAND DRIVE FRONT STEER POWER ONLY

Description	Part#	Price
35-40 Ford Superide II	BX-202-RH	3,671.00
41-48 Ford Superide II	BX-203-RH	3,671.00
37-41 Willys Superide II	BX-211-RH	3,671.00
37-39 Chevy Superide II	BX-212-RH	3,671.00
40-48 Chevy Superide II	BX-213-RH	3,671.00
40-46 Chevy Pick up Superide II	BX-305-RH	3,671.00
47-54 Chevy Pick up Superide II	BX-306-RH	3,671.00

Product is painted for catalog purposes only! All kits ship with Silver Powder Coated Springs - not shown.



BX-202-RH

CLASSIC TRUCK SUPERIDE II RIGHT HAND DRIVE FRONT STEER, 60" TRACK POWER ONLY

Description	Part#	Price
55-59 Chevy Pick up	BX-307-RH	3,995.00
48-52 Ford F-1	BX-310-RH	3,995.00
53-63 Ford F-1	BX-316-RH	3,995.00

Product is painted for catalog purposes only! All kits ship with Silver Powder Coated Springs - not shown.



BX-307-RH

STREET ROD MUSTANG II RIGHT HAND DRIVE FRONT STEER POWER ONLY

Description	Part#	Price
34-35 Chevy standard	CX-101-E-K-RH	2,807.00
37-39 Chevy	CX-102-E-K-RH	2,807.00
40-48 Chevy	CX-103-E-K-RH	2,807.00
49-54 Chevy	CX-104-E-K-RH	2,807.00
34-36 Chevy Master	CX-111-E-K-RH	2,807.00
37-39 Chevy Pick Up	CX-305-E-K-RH	2,807.00
40-46 Chevy Pick Up	CX-306-E-K-RH	2,807.00
47-54 Chevy Pick Up	CX-307-E-K-RH	2,807.00
55-59 Chevy Pick Up 60" track	CX-308-E-K-RH	2,807.00
Universal 56-1/2" track	KX-101-E-K-RH	2,807.00
Universal 60" track	KX-102-E-K-RH	2,807.00
33-34 Ford	PX-101-E-K-RH	2,807.00
35-40 Ford	PX-102-E-K-RH	2,807.00
41-48 Ford	PX-103-E-K-RH	2,807.00
48-52 Ford F-1, 60" track	PX-104-E-K-RH	2,807.00
53-63 Ford F-1, 60" track	PX-105-E-K-RH	2,807.00

Product is painted for catalog purposes only! All kits ship with Silver Powder Coated Springs - not shown.



BX-101-E-K-RH



Order/Tech: 800-841-8188

HEIDTS® STREET ROD PARTS

HEIDTS SUPERIDE® IRS

MADE FOR BOTH HOT ROD & MUSCLE CAR APPLICATIONS!

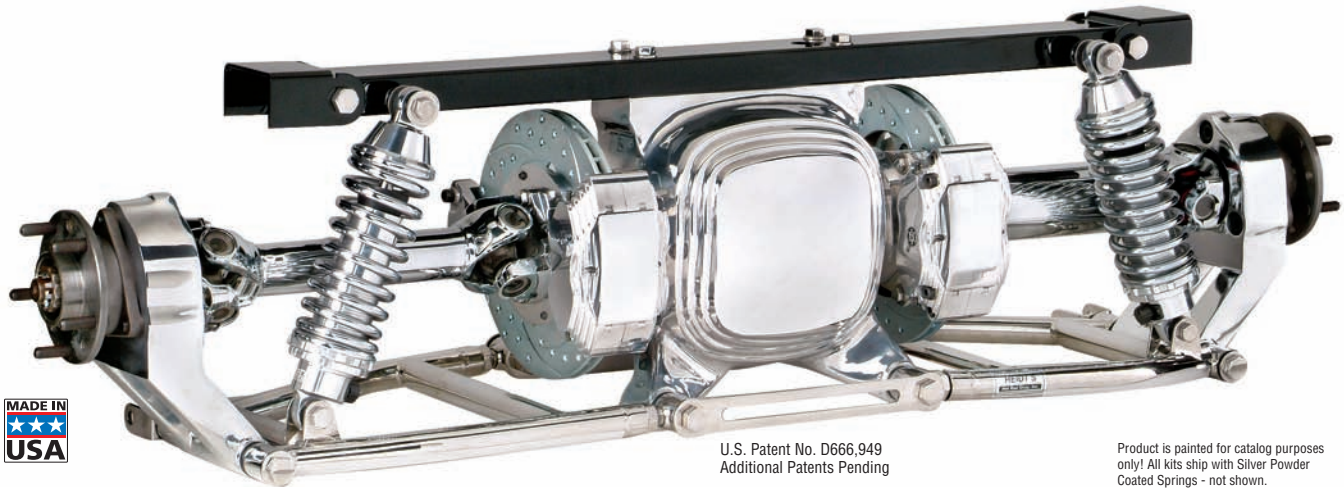

U.S. Patent No. D666,949
Additional Patents Pending

Product is painted for catalog purposes only! All kits ship with Silver Powder Coated Springs - not shown.

Get the best handling for your Street Rod or Muscle Car with **HEIDTS SUPERIDE®** Independent rear suspension kit. The best riding and handling IRS to combine with your SUPERIDE® IFS to make your Street Rod or Muscle Car a first class ride. The geometry is designed to be compatible with all of our independent front suspensions, as well as most other independent front suspension kits. It is a complete kit, hub to hub and with added options your Street Rod or Muscle Car will be the hottest ride in town.

INCLUDED IN BASE KIT:

- Top Crossmembers • Lower Arms
- Aluminum Uprights • 2" Half Shafts
- 9" Aluminum Housing • 3rd Member, Iron, Open
- 10.5" Wilwood Rotors with 4 Piston Polished Calipers
- Billet Single Adjustable Coil-Over Shocks with Silver Powder Coated Springs

Now with Silver Powder Coated Springs! Powder coating does not rust or peel while saving you money!



COMPLETE BASE KIT

Available Track Widths: 55", 56", 58", 60", 62"

Description	Part#	Base Price
Plain Rotors	BR-101	7,974.00
Drilled Rotors	BR-101-D	8,316.00

HOUSING OPTIONS

Description	Part#	Add
Plain Housing	BM-001	Included
Polished Housing	BM-001-P	205.00

UPRIGHTS OPTIONS

Description	Part#	Add
Plain Uprights, Plain Bearings, 4.75 Bolt Pattern	BM-002	Included
Plain Uprights, Chrome Bearings, 4.75 Bolt Pattern	BM-002-C	329.00
Plain Uprights, Plain Bearings, 4.50 Bolt Pattern	BM-002-F	59.00
Plain Uprights, Chrome Bearings, 4.50 Bolt Pattern	BM-002-F-C	389.00
Polished Uprights, Plain Bearings, 4.75 Bolt Pattern	BM-002-P	314.00
Polished Uprights, Chrome Bearings, 4.75 Bolt Pattern	BM-002-P-C	643.00
Polished Uprights, Plain Bearings, 4.50 Bolt Pattern	BM-002-F-P	373.00
Polished Uprights, Chrome Bearings, 4.50 Bolt Pattern	BM-002-F-P-C	702.00

PINION SUPPORT & STRUTS OPTIONS

Description	Part#	Add
Plain Pinion Support & Struts	BM-003	Included
Polished Pinion Support & Struts	BM-003-P	259.00

CONTROL ARM OPTIONS

Description	Part#	Add
Plain Lower Arms	BM-004-XX	Included
Polished Lower Arms	BM-004-XX-P	1,512.00
Plain Lower Arms, Dual Shocks	BM-004-XX-D	194.00
Polished Lower Arms, Dual Shocks	BM-004-XX-P-D	1,442.00

XX = Track Width Available: 55", 56", 58", 60", 62"

OPTIONS

HEIDTS SUPERIDE® IRS

Owner: Don Barnes, The Performance Center



CROSSMEMBER OPTIONS

Description	Part#	Add
28", 32", 36", 40" Crossmember & Plain Forward Struts	BM-005-XX	Included
28", 32", 36", 40" Crossmember & Polished Forward Struts	BM-005-XX-P	376.00
Crossmember, Model A, Plain Forward Struts	BM-005-28	70.00
Crossmember, Model A, Stainless Steel Forward Struts	BM-005-28-P	376.00
32" Crossmember for 56" Track Width & Plain Struts	BM-005-32	70.00
32" Crossmember for 56" Track Width & Polished Struts	BM-005-32-P	376.00
Special Crossmember	BM-005-SPEC	65.00

XX = Crossmember Width

HALF SHAFT OPTIONS

Description	Part#	Add
2" Plain Half Shafts	BM-006-XX	Included
2" Chrome Half Shafts	BM-006-XX-C	747.00
2" Chrome Half Shafts W/Chrome U-joints	BM-006-XX-C-X	884.00
3" Heavy Duty Plain Half Shafts	BM-006-XX-3	257.00
3" Heavy Duty Chrome Half Shafts	BM-006-XX-3-C	1,003.00

Chrome U-joint not available with 3" chrome half shafts.
XX = Track Width Available: 55", 56", 58", 60", 62"

COIL-OVER SHOCK OPTIONS

Description	Part#	Add
Plain Billet Coil-Over Shocks	CB-101	Included
Polished Billet Coil-Over Shocks	CB-101-P	86.00

COIL-OVER SPRING OPTIONS

Description	Part#	Add
400#, 450#, 500#, 550#, 600#, 700# Silver Powder Coated 9" Springs	CS-XXX-09	Included

3RD MEMBER OPTIONS

Description	Part#	Add
Open 31 Spline Any Ratio	BN-XXX-I	Included
Positraction 31 Spline Any Ratio	BN-XXX-I-L	864.00
Open 31 Spline Any Ratio, Aluminum Case	BN-XXX-P	1,836.00
Positraction 31 Spline Any Ratio, Aluminum Case	BN-XXX-P-L	2,328.00
3rd Member Case - Use w/ Polished Aluminum Case	BN-001	43.00

Now you can complete your parking brake cable hook-up with HEIDTS® new E-Brake Bracket and Cable Kit. The complete kit consists of Lokar's 10' Universal Black Parking Brake Cable set and HEIDTS® bolt-on Brackets. They bolt right on to the parking calipers, and the cables complete the installation easily. The brackets are available separately.

PARKING BRAKE OPTIONS

Description	Part#	Add
Polished Pinion Yoke With Chrome U-Bolts	BT-063-P	425.00
Parking Brake Kit & Cable Kit - Black	PB-101	589.00
Parking Brake Kit & Cable Kit - Silver	PB-101-S	589.00
E-Stop Actuator	BM-013	699.00

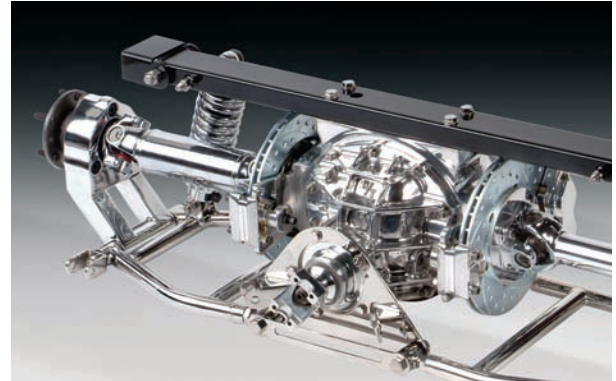

Polished Stainless Lower Arms with Polished Adjusters and Polished Stainless Tie Bars, Polished Center Housing, Polished Outer Uprights

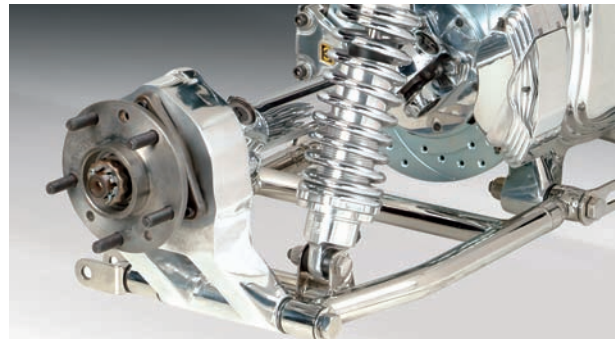

HIGH HORSEPOWER HALF SHAFTS

Designed for muscle car and heavy car applications. 3" dia. tubes will take extra torque loads.

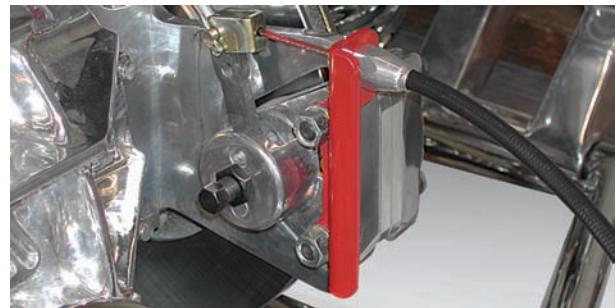

Order/Tech: 800-841-8188

HEIDTS® STREET ROD PARTS

**OUR KITS ARE PRE-FITTED, READY TO INSTALL!
NO MISTAKES, EVERYTHING'S PRE-CUT.**



**MUSTANG II
CROSSMEMBERS**



- One-Piece Shock Cups are T.I.G welded in place. First class, for your car.
- Built-in Anti-Dive is all fitted to your frame... No Grinding Required! Nothing to measure or trim...It's All Done!
- Vertical Inner Uprights. This is the strongest design available, with twice the weld area. This will keep your frame from twisting!
- Main Crossmember made from only 2 Formed Pieces for maximum strength and Accurate Fit. This is VERY important!
- Crossmember and Spring Towers precut and pre-welded to fit your frame... Nothing to Measure!



UNIVERSAL MUSTANG II CROSSMEMBERS

UNIVERSAL MUSTANG II CROSSMEMBERS FOR 56 1/2" OR 60" TRACK WIDTH VEHICLES

This kit fits larger vehicles that have a 60" track width. It is intended for use with our 4" Rack Extension Kit to keep the geometry straight.

56 1/2" track width crossmembers fit frame rail from 24" to 30"
60" track width crossmembers fit frame rail from 27 1/2" to 33 1/2"
(Outside to outside frame dimensions)

Description	Part#	Price
56-1/2" Track Width Crossmember	KX-101-E	430.00
60" Track Width Crossmember *Rack Extension Kit Required	KX-102-E	430.00
56-1/2" Track Width Crossmember for Full A-Frame Lower	KX-101-E-K	485.00
60" Track Width Crossmember for Full A-Frame Lower	KX-102-E-K	485.00

MUSTANG II CROSSMEMBERS

These crossmembers are individually designed for the '64 1/2 to '70 Mustang, '67 to '70 Cougar and '60 to '65 Falcon. They include full front section boxing plates that weld into place. The correct geometry and anti-dive is all designed in for superior handling and ease of operation. **HEIDTS® 2"** Dropped Spindle recommended to retain stock ride height.

Description	Part#	Price
64 1/2 - 70 Mustang / 67 - 70 Cougar	PX-320-E-K	539.00
60 - 65 Falcon	PX-330-E-K	539.00

SUBFRAME / CROSSMEMBER ASSEMBLY - ONLY

Description	Part#	Price
Subframe/Crossmember Assembly	CX-320-S	755.00
Crossmember Only	CX-320-E	430.00



THE FORD GEOMETRY IS ALREADY BUILT IN. NOTHING TO CUT, JUST WELD IN PLACE!

FORD IFS

Our Mustang IFS kits for Fords are natural conversions for the Ford frames. We retain all the factory dimensions and locations, so you get all the benefit of Ford engineering in your front end. There's absolutely no reason to widen or otherwise modify the Ford design or use long tie rod ends!

These kits fit the frames easily and yield a 3"-4" suspension drop.

Included in most kits are all the special, hard-to-make brackets and mounts you will need to complete the installation, plus HEIDTS® own illustrated installation booklet.

We don't make a Mustang conversion kit for the Model A or '32 Ford. See our Superide IFS kits for these cars. These cars, because of their direct mounting low fenders, require modifying the Ford IFS design by relocating the upper control arm inner pivot to clear the fender, causing a very noticeable amount of bumpsteer! Turn to the Tech info on page 75 for more detailed information on this subject.

UNIVERSAL MUSTANG II CROSSMEMBERS

Put a HEIDTS® Mustang II crossmember in your car! Using our Multi-fit Mustang II Crossmember Kit you can now adapt the very popular Mustang II suspension with HEIDTS® correct geometry into almost any application. The crossmember and spring towers are made oversized to allow trimming and fitting to your particular frame size. Templates and instructions, designed for a home builder to install, walk you through the entire installation to insure that you get correct anti-dive and geometry.

CHEVY IFS

The Chevy models shown here also have frames and fenders which lend themselves nicely to Mustang front end conversion, without changing the critical geometry. Chevy IFS kits also come complete with the hard-to-make special brackets, such as radiator perch on certain models, to quickly and easily complete the installation. And naturally, like our Ford kits, Chevy kits do not bumpsteer at all. See our Tech info on page 75 of this catalog for a more detailed explanation of the hazards of bumpsteer

OUR IFS KITS RETAIN ALL THE ORIGINAL SUSPENSION FEATURES!

- Longer tie rod ends aren't used – ever!
- Mounting points of all control arms match the original ford design.
- Factory anti-dive built right in.

Chevy kits also come with a step-by-step, fully-illustrated instruction booklet to ensure that your installation goes as easily as it should!

INSTALLATION BOOKLET

Included in most kits are all the special, hard-to-make brackets and mounts you will need to complete the installation, and all have a step-by-step illustrated installation booklet.

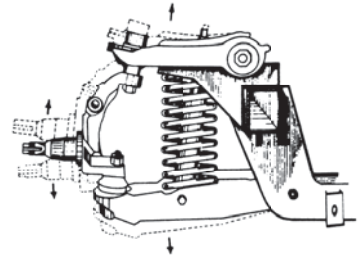

Correct design results in correct camber action – and no bumpsteer

 <p>'33-'34 Ford Car PX-101-E, 430.00</p> <ul style="list-style-type: none"> • Upper fender adapter brackets included! Radiator tabs included! • Manual Steering & Tube Arms Only 	  <p>'35-'40 Ford Car '35-'41 Ford Pick-Up PX-102-E, 430.00</p> <ul style="list-style-type: none"> • Boxing Plates Included • Narrowed Arms Recommended 	   <p>'41-'48 Ford Car PX-103-E, 430.00</p> <p>'48-'52 Ford F-1 <i>Rack Extension Required</i> PX-104-E, 430.00</p> <p>'53-'64 Ford F-100 <i>Rack Extension Required</i> PX-105-E, 430.00</p> <p>MP-037-1-4 Manual Rack Extension</p> <p>MP-039-4 Power Rack Extension</p>	  <p>'34-'35 Chevy Standard Car CX-101-E, 430.00</p> <p>'34-'36 Chevy Master Car CX-111-E, 430.00 Cars Only!</p> <ul style="list-style-type: none"> • Radiator Mount included. • Manual Steering & Tube Arms Only 	   <p>'37-'39 Chevy Car CX-102-E, 430.00</p> <p>'40-'48 Chevy Car CX-103-E, 430.00</p> <p>'49-'54 Chevy Car CX-104-E, 430.00</p>	    <p>'37-'39 Chevy Pick-Up CX-305-E, 430.00</p> <p>'40-'46 Chevy Pick-Up CX-306-E, 430.00</p> <p>'47-'54 Chevy Pick-Up CX-307-E, 430.00</p> <p>'55-'59 Chevy Pick-Up* <i>Rack Extension Required</i> CX-308-E, 430.00</p> <p>Trucks Only! • C-notched Plates included.</p>
<p>Strut Plates and Gussets for stock control arms available separately (Specify Application)</p> <p>MP-003 \$25</p> 		<p>Air Ride Available For Most Applications Call For Details.</p>			



HEIDTS® MUSTANG II



Product is painted for catalog purposes only!

INCLUDED IN BASE KIT:

- HEIDTS® Crossmember • Stock Height Spindles • Tubular Upper & Lower Arms
- 11" Rotors with Single Piston Calipers
- Stock Shocks and Springs

Now with Silver Powder Coated Springs! Powder coating does not rust or peel while saving you money!

COMPLETE BASE KIT STARTING AT \$2,267

COMPLETE BASE KIT \$2,267

Description	Part#	Description	Part#
34-35 Chevy	CX-101-E-K	Multi-Fit 56" Track Width	KX-101-E-K
37-39 Chevy Car	CX-102-E-K	Multi-Fit 60" Track Width****	KX-102-E-K
40-48 Chevy Car	CX-103-E-K	33-34 Ford Car ###	PX-101-E-K
49-54 Chevy Car	CX-104-E-K	35-40 Ford Car/35-41	
34-36 Chevy Master	CX-111-E-K	Ford Pick-Up <<<	PX-102-E-K
37-39 Chevy Pick-Up	CX-305-E-K	41-48 Ford Car	PX-103-E-K
40-46 Chevy Pick-Up	CX-306-E-K	48-52 Ford Pick-Up****	PX-104-E-K
47-54 Chevy Pick-Up	CX-307-E-K	53-56 Ford F100****	PX-105-E-K
55-59 Chevy Pick-Up****	CX-308-E-K		

****Rack Extension Required, ### Tube Arms & Manual Rack Only, <<< Narrowed Arms Recommended

CONTROL ARM OPTIONS

Description	Part#	Add
Tubular Arms (Narrowed available)	CA-112	Included
Stainless Steel Tubular Arms (Narrowed available)	CA-112-SS	1,188.00

BRAKE OPTIONS

Description	Part#	Add
11" Iron Rotors & GM Calipers	DF-201-B-G or F-G	Included
12" Wilwood Drilled Rotors & 4 Piston Polished Calipers	DF-208-P-K	1,127.00
13" Wilwood Drilled Rotors & 6 Piston Polished Calipers	DF-206-P-K	1,896.00

Additional options available. Call for pricing.

SPINDLE OPTIONS

Description	Part#	Add
Stock Spindles	MP-028	Included
2" Dropped Spindles	SP-101-K	Included

RACK & PINION OPTIONS

Description	Part#	Add
Manual Rack & Pinion	MP-018-K	Included
Power Rack & Pinion	MP-038-3-K	140.00
Power Rack W/ Stainless Steel Tie Rod Ends	MP-038-SS-K	275.00

SHOCK & SPRING OPTIONS

Description	Part#	Add
275# - 375# Springs & Stock Shocks	MP-007-XXX-K	Included
275# - 375# Springs & Coil-Over Shocks	MP-050-XXX-K	486.00
Thrust Bearings For Coil-Over Shocks	CQ-010	40.00
Spanner Wrench	TA-001	18.00

ADDITIONAL OPTIONS

Description	Part#	Price
Polished Stainless Steel Ball Joint Caps, Pair	MP-035	66.00
Polished Stainless Steel Ball Joint Caps, TALL, Pair	MP-034	66.00
Polished Stainless Steel Tie Rod Ends, Pair	MP-017-SS	132.00
Aluminum Caliper Covers, Pair	DF-056	135.00

CA-101-E-K



CA-112-SS

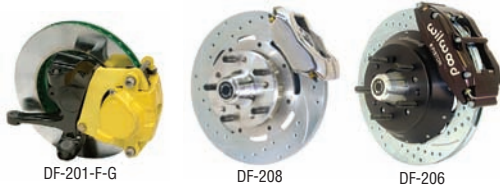

DF-201-F-G

DF-208

DF-206

MP-038-3-K



TA-001



SP-101-K

MP-035

MP-017-SS

OPTIONS

HEIDTS® MUSTANG II

Owner: Scott Diedrich,
Builder: Custom Classics
Island Lake, Illinois



DELUXE SUSPENSION PACKAGE WITHOUT CROSSMEMBER

All packages include tubular upper & lower control arms, 11" five lug rotors, bearings, seals, springs, shocks, stock spindles, GM calipers with brackets and pads, manual rack with tie rod ends and bushings, rubber spring cushions, spindle nut kit, and all mounting hardware.

Description	Part#	Price
Plain Tubular Arms	MP-101-B1	1,782.00
Plain Tubular Arms For Coil-Overs	MP-101-B2	1,782.00
Narrowed Plain Tubular Arms	MP-101-B3	1,782.00
Narrowed Plain Tubular Arms For Coil-Overs	MP-101-B4	1,782.00
Stainless Steel Tubular Arms	MP-101-B5	2,916.00
Stainless Steel Tubular Arms For Coil-Overs	MP-101-B6	2,916.00
Narrowed Stainless Steel Tubular Arms	MP-101-B7	2,916.00
Narrowed Stainless Steel Tubular Arms For Coil-Overs	MP-101-B8	2,916.00



MUSTANG II

11" Billet Brake Kit includes Wilwood 4 Piston Calipers and Plain or Crossdrilled & Slotted Rotors. 12" Big Brake Kit with Wilwood 4 Piston Calipers, Polished Aluminum Hubs with Crossdrilled & Slotted Rotors.

11" & 12" 4 PISTON MUSTANG II BRAKES

Description	Part#	Price
11" Wilwood Smooth Rotors & 4 Piston Black Calipers	DF-202-B	897.00
11" Wilwood Smooth Rotors & 4 Piston Polished Calipers	DF-202-P	897.00
11" Wilwood Smooth Rotors & 4 Piston Red Calipers	DF-202-RED	897.00
11" Wilwood Drilled Rotors & 4 Piston Black Calipers	DF-202-D-B	1,124.00
11" Wilwood Drilled Rotors & 4 Piston Polished Calipers	DF-202-D-P	1,124.00
11" Wilwood Drilled Rotors & 4 Piston Red Calipers	DF-202-D-RED	1,124.00
12" Wilwood Drilled Rotors & 4 Piston Black Calipers	DF-208-B	1,117.00
12" Wilwood Drilled Rotors & 4 Piston Polished Calipers	DF-208-P	1,127.00
12" Wilwood Drilled Rotors & 4 Piston Red Calipers	DF-208-RED	1,136.00



MUSTANG II 2" DROPPED STEEL SPINDLES

Description	Part#	Price
Stock Spindles	MP-028	206.00
2" Dropped Spindles	SP-101-K	206.00



TUBULAR STRUT ROD KIT

HEIDTS® offers a universal kit for factory style lower arms. You only have to notch the strut mount plates to meet your frame rail. Kit comes complete with bushings and mounting hardware.

Description	Part#	Price
Plain Tubular Strut Rod Kit	SR-101	111.00
Polished Stainless Steel Tubular Strut Rod Kit	SR-101-SS	341.00
44 Degree Tubular Replacement Rod Kit (Pinto)	SR-020	114.00
52 Degree Tubular Replacement Rod Kit (Mustang II)	SR-021	108.00



Order/Tech: 800-841-8188

HEIDTS® STREET ROD PARTS

HEIDTS® MUSTANG II

Upper A-Arms (Pair)

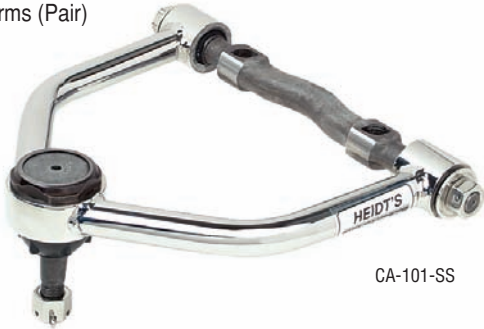

CA-101-SS

TUBULAR UPPER A-ARMS

Tubular Upper A-Arms are the ultimate in looks. Direct replacement for stock upper-A-arms, providing more clearance for stock sheet metal. All welds are TIG welded for maximum strength and appearance. Fits **HEIDTS®** and most other IFS kits. Arms arrive fully assembled, ready to install, including ball joints, bushings and cross shafts.

Description	Part#	Price
Plain Tubular A-Arms	CA-101	280.00
Polished Stainless Steel Tubular A-Arms	CA-101-SS	611.00



CA-103-SS-N-S

NARROWED UPPER & LOWER ARMS

Narrowed Upper and Lower Full A-Arms. More tire to fender clearance for deep offset wheels, as they are narrowed 5/8" per side. Must be used in sets of uppers and lowers.

Description	Part#	Price
Narrowed Plain Upper A-Arms	CA-101-N	280.00
Narrowed Polished Stainless Steel Upper A-Arms	CA-101-SS-N	611.00
Narrowed Plain Lower A-Arms With Swaybar Mounts	CA-103-N-S	475.00
Narrowed Polished Stainless Steel Lower A-Arms With Swaybar Mounts	CA-103-SS-N-S	1,252.00
Narrowed Plain Lower Coil-Over A-Arms With Swaybar Mounts	CA-103-N-M-S	475.00
Narrowed Polished Stainless Steel Lower Coil-Over A-Arms With Swaybar Mounts	CA-103-SS-N-M-S	1,252.00

CA-102-SS



TUBULAR LOWER CONTROL ARMS

These Tubular Lower Control Arms are direct replacement for factory lower control arms. Uses stock Mustang II, springs and strut rods. Arms arrive fully assembled ready to install, with lower shock bolts and nuts. Ball joints and bushings installed. All TIG welded for maximum strength and appearance. Fits all **HEIDTS®** Mustang II IFS kits as well as most other after market Mustang II kits.

Description	Part#	PRICE
Plain Arms	CA-102	334.00
Polished Stainless Steel Arms	CA-102-SS	918.00



CA-240

MUSTANG II REPLACEMENT PARTS

Description	Part#	PRICE
Bushing Assembly, Upper	CA-240	11.00
Bushing Assembly, Lower	CA-241	11.00
Heidts Mustang II Tubular Control Arm Ball Joint Boots	CA-029	4.00
Heidts Superide / Superide II Control Arm Replacement Urethane Bushings	BX-017	7.00



Lower A-Arms (Pair)

CA-103-SS-S

TUBULAR LOWER A-ARMS

Full A-Arm Lower Control Arm uses no strut rod! Triangulated A-Arm design, similar to factory G.M. control arms, provides stability and strength within the arm itself. All welds are TIG welded for ultimate strength and appearance. Comes complete, ready to install with mounting bolts, spacers, shock bolts, nuts, installed ball joints and bushings.

Description	Part#	Price
Plain Tubular A-Arms With Swaybar Mounts	CA-103-S	475.00
Polished Stainless Steel Tubular A-Arms With Swaybar Mounts	CA-103-SS-S	1,252.00

HEIDTS® MUSTANG II

COIL-OVER LOWER ARMS

Now available – Lower Tubular Control Arms designed exclusively for coil-overs. These arms will accept any standard aftermarket coil-over shock. Available in steel or polished stainless steel for the ultimate in appearance.

Description	Part#	Price
Plain Coil-Over Arms With Swaybar Mounts	CA-103-M-S	475.00
Polished Stainless Steel Coil-Over Arms With Swaybar Mounts	CA-103-SS-M-S	1,252.00
Plain Coil-Over A-Arms	CA-102-M	334.00
Polished Stainless Steel Coil-Over A-Arms	CA-102-SS-M	692.00



STABILIZER BARS

Description	Part#	Price
Front		
35-40 Ford*	SB-001	200.00
37-39 Chevy	SB-003	200.00
40-48 Chevy	SB-004	200.00
49-54 Chevy	SB-005	200.00
47-54 Chevy Pick-Up	SB-054	200.00
41-48 Ford	SB-006	200.00
48-54 Ford Pick-Up & 53-56 Ford F100	SB-007	200.00
Rear		
35-40 Ford (Twin Leaf)	SB-002	200.00
Universal Rear	SB-009	287.00

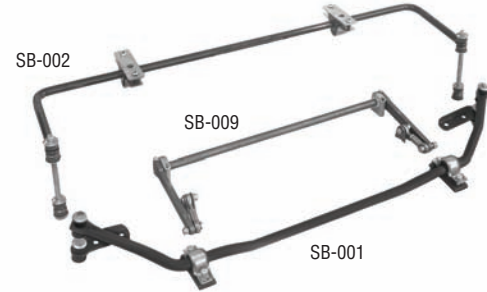

*SB-001 fits '33-'34 Ford with relocation of mounting holes in frame.
Note: These bars can fit numerous applications with modifications to mounts.

HEIDTS® SUPERIDE BILLET MUSTANG II COIL-OVERS

Description	Part#	Price
HEIDTS® Mustang II Coil-Over Shocks Pr.	MP-050	580.00
HEIDTS® Mustang II Coil-Over Shocks Pr. Polished	MP-050-P	654.00
375# Silver Powder Coated Coil Springs, Pair	MP-041	125.00
500# Silver Powder Coated Coil Springs, Pair	MP-042	125.00
600# Silver Powder Coated Coil Springs, Pair	MP-043	125.00
700# Silver Powder Coated Coil Springs, Pair	MP-044	125.00



HEIDTS® AIR SHOCK SUSPENSION SYSTEM

Now add air ride comfort and the ultimate in coolness to your muscle car or street rod with HEIDTS® Air Shock Suspension System. You can cruise in the smoothest ride around to your rod run, and with just a touch of a button drop your street rod 2"-3". When it is time to go home, just pump up the suspension and float on home. HEIDTS® Air Shock Suspension System does it all. Kit includes new lower air spring control arms, shocks, upper shock mounts, upper air spring adapters, and air springs.

Description	Part#	Price
HEIDTS® Air Shock Upgrade Kit	AS-110	469.00

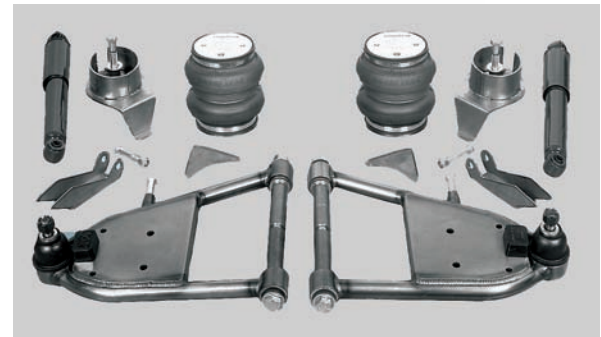
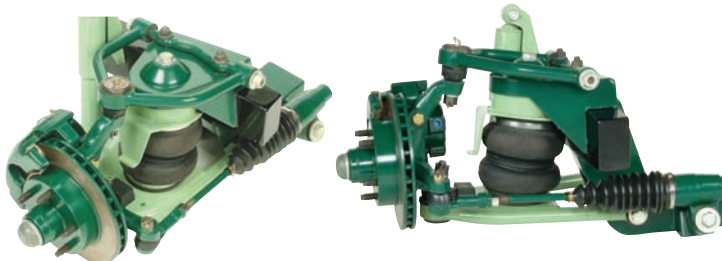

HEIDTS®
SUSPENSION SYSTEMS

Order/Tech: 800-841-8188

HEIDTS® STREET ROD PARTS

HEIDTS SUPERIDE®

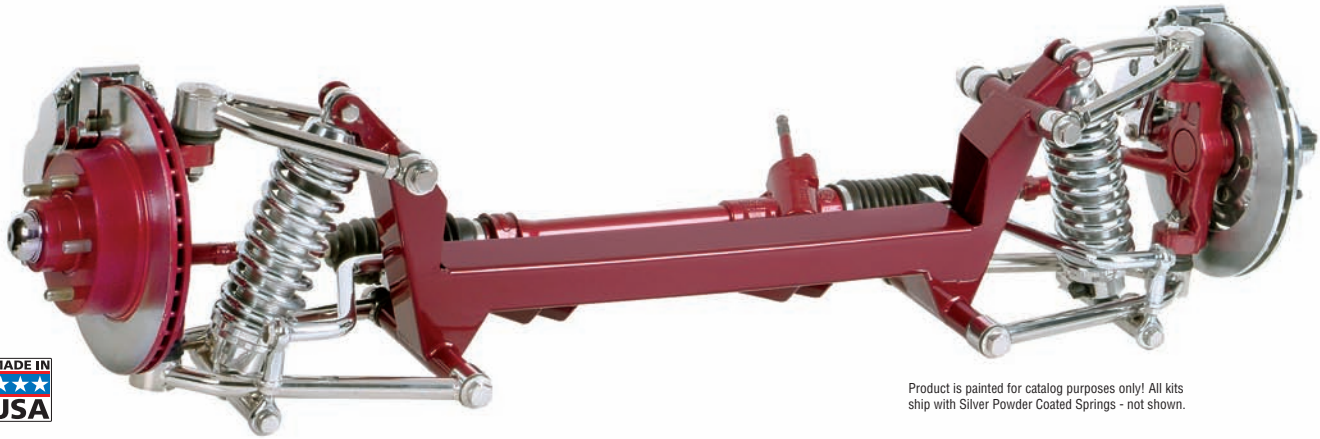

Product is painted for catalog purposes only! All kits ship with Silver Powder Coated Springs - not shown.

COMPLETE BASE KIT STARTING AT \$3,369.00

INCLUDED IN BASE KIT:

- HEIDTS® Crossmember
- Superide Spindles
- Tubular Upper & Lower Arms, Standard or Narrowed
- 11" Rotors with 4 Piston Wilwood Calipers
- Manual Rack & Pinion Steering
- Billet Single Adjustable Coil-Over Shocks with Silver Powder Coated Springs

Now with Silver Powder Coated Springs! Powder coating does not rust or peel while saving you money!



ALL NEW SUPERIDE-NOT A MUSTANG CONVERSION KIT!

Because this Independent Front Suspension was designed as a complete system, the individual components are not interchangeable with any other stock pieces. Every piece was designed specifically by HEIDTS® for the SUPERIDE systems. It's your assurance of the right geometry, the right fit, and of course — a super ride!

Final ride height from spindle to bottom of frame: `28-`35 Chevy = 1-1/2"
 `32 Ford = 2-1/2", `33-`34 & "A" Ford = 2"

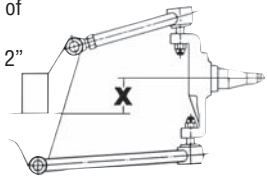

HEIDTS® IFS IS BETTER

Independent Front Suspension gives you twice the ride of a new 4-link dropped axle at a comparable cost. It adds more cash value to your car than any other type of suspension. With HEIDTS® engineering you get an unmatched, correct, safe ride. HEIDTS® SUPERIDE complete system is perfect for the ultimate stance! Shipped by UPS, our SUPERIDE arrives complete hub to hub with no other parts to buy.

SMOOTH SAILING

"Smooth" describes the ride: very low and highly steerable with no bumpsteer and built-in anti-dive. Installing the one piece crossmember is an easy one-step operation. The upper control arms are designed to clear the fenders. The 56" hub to hub tread width gives you the narrow look without any tire to fender clearance problems.

HEIDTS® EXCLUSIVE SUPERIDE SPINDLE

This is not a Mustang dropped spindle. HEIDTS® has designed its own one piece spindle specifically for the SUPERIDE. So, now you can get the lowest ride available that's tops in looks and safety! It's clean and trim adding to the high tech appearance you want for your front end. For peace of mind we've made it out of 1045 heat treated alloy steel.

COMPLETE BASE KIT

Description	Part#	Base Price
27-31 Model A Ford	BX-101	3,369.00
32 Ford	BX-102	3,369.00
33-34 Ford	BX-103	3,369.00
28-35 Chevy - Use W/ Narrowed Control Arms	BX-114	3,369.00

OPTIONS

HEIDTS SUPERIDE®

Owner: Claire Ball
Falcon Hot Rods



HEIDTS® STREET ROD PARTS

CONTROL ARM OPTIONS

Description	Part#	Add
Tubular Arms (Narrowed available)	BS-005	Included
Stainless Steel Tubular Arms (Narrowed available)	BS-006	1,096.00

BRAKE OPTIONS

Description	Part#	Add
11" Iron Rotors, Wilwood 4 Piston Polished Calipers, Chevy Bolt Pattern	BS-008-K	Included
11" Iron Rotors, Wilwood 4 Piston Polished Calipers, Ford Bolt Pattern	BS-009-K	Included
11" Iron Rotors, GM Calipers, 5" Bolt Pattern	BS-009-5-K	75.00
11" Wilwood Smooth Rotors & 4 Piston Polished Calipers W/ Polished Hubs	BS-020-K	480.00
11" Wilwood Drilled Rotors & 4 Piston Polished Calipers W/ Polished Hubs	BS-020-D-K	605.00
12" Wilwood Drilled Rotors & 4 Piston Polished Calipers W/ Polished Hubs**	DF-209-K	900.00
13" Wilwood Drilled Rotors & 6 Piston Black Calipers W/ Black Hubs**	DF-207-B	1,905.00
13" Wilwood Drilled Rotors & 6 Piston Polished Calipers W/ Black Hubs**	DF-207-P	1,905.00

**12" or 13" Optional Brake Packages Require Optional Stainless Steel Spindles

SPINDLE OPTIONS

Description	Part#	Add
Superide Chromoly Alloy Steel Spindles	BS-007	Included
Polished Stainless Steel Spindles For 12" & 13" Brake Kits	BS-012	275.00
Polished Stainless Steel Spindles W/Aluminum Brackets For 11" Brake Kits	BS-0125-S	394.00

RACK & PINION OPTIONS

Description	Part#	Add
Manual Rack & Pinion	BS-004	Included
Manual Rack & Pinion W / Stainless Steel Tie Rod Ends	BS-004-SS	135.00
Billet Manual Rack & Pinion	BS-004-B-K	767.00
Billet Manual Rack & Pinion W/ Stainless Steel Tie Rod Ends	BS-004-B-SS-K	861.00
Power Rack & Pinion	BS-004-PS-K	288.00
Power Rack W/Stainless Steel Outer Tie Rod Ends	BS-004-PS-SS-K	370.00

SHOCK & SPRING OPTIONS

Description	Part#	Add
400#, 450#, 500#, 550# Springs/Plain Billet Coil-Over Shocks	BS-001-XX	Included
400#, 450#, 500#, 550# Springs/Polished Billet Coil-Over Shocks	BS-002-XX	86.00
Thrust Bearings For Coil-Over Shocks	CQ-010	40.00
Spanner Wrench	TA-001	18.00

ADDITIONAL OPTIONS

Description	Part#	Price
Power Steering Valve	PS-101	97.00
11" Polished Rotor Covers for Stainless Steel Spindles - Must Use BS-012 Spindles, Pair	BS-010	324.00
12" Polished Rotor Covers for Stainless Steel Spindles - Must Use BS-012 Spindles, Pair	BS-018	605.00
Swaybar	BS-055	200.00
Chrome Swaybar	BS-055-C	470.00
Polished Caliper Covers, Pair	DF-056	189.00
14" Braided Stainless Steel Brake Line Kit	BX-055	39.00
Polished Stainless Steel Ball Joint Caps, Pair	BS-029	65.00
Power Steering Hose Kit for Superide Integral Reservoir	PS-116	206.00
Power Steering Hose Kit for Superide Remote Reservoir	PS-117	236.00

BS-006



BS-020



BS-020-D



DF-209



DF-207-B



BS-010, BS-018



BS-012



BX-055



BS-029

Order/Tech: 800-841-8188

HEIDTS®
SUSPENSION SYSTEMS

HEIDTS SUPERIDE® OPEN WHEEL

HEIDTS SUPERIDE® OPEN WHEEL



BX-105

Product is painted for catalog purposes only! All kits ship with Silver Powder Coated Springs - not shown.

HEIDTS SUPERIDE® INBOARD SHOCK

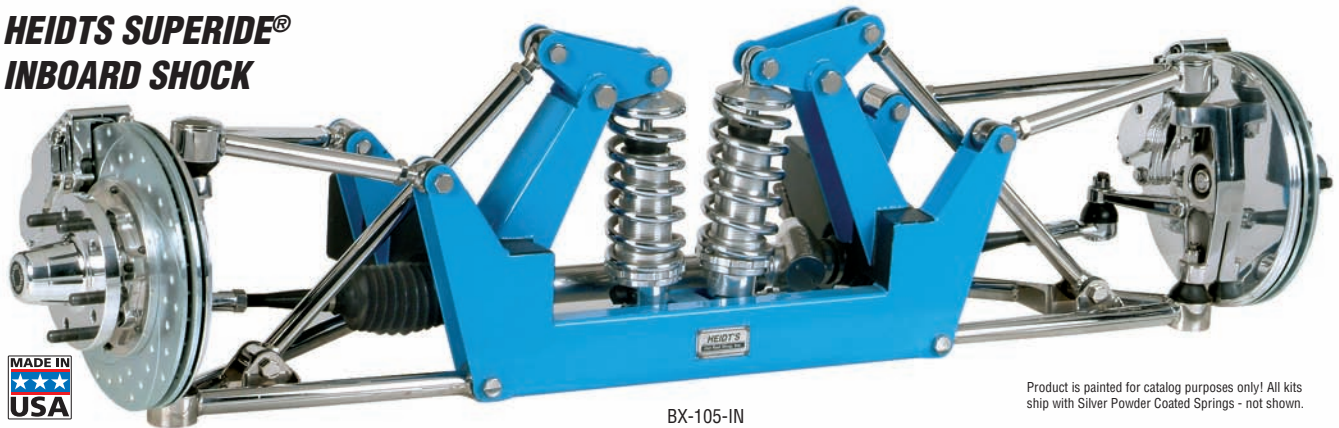

BX-105-IN

Product is painted for catalog purposes only! All kits ship with Silver Powder Coated Springs - not shown.

HEIDTS® IFS IS BETTER

Our HEIDTS SUPERIDE® Open Wheel is designed for fenderless cars with pinched rails. The swept back style control arms, with the front tubes in line with the axle center are longer to meet up closer to the frame rails. The kit is designed for rails pinched to approximately 20" wide at axle center line, which is what a '32 Ford grill shell is. Ride height will be 1.25" lower than regular Superide to have that nice lowrider look so popular with fenderless cars. Control arms are available in mild steel and polished stainless steel. Shocks are available in plain or polished. Springs are chrome on all models. All kits come with Wilwood polished aluminum 4-piston calipers. Also available is our polished aluminum hub option, the finishing touch for a front suspension of this caliber. Hub to hub track width is 56" flange to flange. Both Ford and Chevy bolt patterns are available in both outboard and inboard shock configurations.

These kits are designed for the experienced home builder or shop installation, as frame modifications are required. Rails must be pinched in and c-notching of the rails for the rack boots is required. A radiator with custom lower tank will also be required.

COMPLETE BASE KIT STARTING AT \$3,812

INCLUDED IN BASE KIT:

- HEIDTS® Crossmember • Superide Spindles • Tubular Upper & Lower Arms, Standard or Narrowed
- Manual Rack & Pinion Steering • 11" Rotors with 4 Piston Wilwood Calipers • Billet Single Adjustable Coil-Over Shocks with Silver Powder Coated Springs

Now with Silver Powder Coated Springs! Powder coating does not rust or peel while saving you money!

HEIDTS® EXCLUSIVE SUPERIDE DROPPED SPINDLE

This is not a Mustang dropped spindle. HEIDTS® has designed its own one piece spindle specifically for the HEIDTS SUPERIDE®. So, now you can get the lowest ride available that's tops in looks and safety! It's clean and trim adding to the high tech appearance you want for your front end. For peace of mind we've made it out of 1045 heat treated alloy steel. Also available is our New HEIDTS® Stainless Steel Spindle for the ultimate finishing touch.

COMPLETE BASE KIT

Description	Part#	Base Price
32 Ford Pinched Rails	BX-105	3,812.00
32 Ford Pinched Rails & Inboard Shocks	BX-105-IN	4,039.00
32 Ford Pinched Rails & Inboard Shocks With Stainless Steel Push Rods	BX-105-IN-SS	4,309.00

OPTIONS

HEIDTS SUPERIDE® OPEN WHEEL

Owner: Pete Schmid
Builder: Louvers Unlimited



CONTROL ARM OPTIONS

Description	Part#	Add
Tubular Arms	BS-030	Included
Stainless Steel Tubular Arms	BS-031	826.00

BRAKE OPTIONS

Description	Part#	Add
11" Iron Rotors, Wilwood 4 Piston Polished Calipers, Chevy Bolt Pattern	BS-008-K	Included
11" Iron Rotors, Wilwood 4 Piston Polished Calipers, Ford Bolt Pattern	BS-009-K	Included
11" Iron Rotors, GM Calipers, 5" Bolt Pattern	BS-009-K-5	75.00
11" Wilwood Smooth Rotors & 4 Piston Polished Calipers W/ Polished Hubs	BS-020-K	480.00
11" Wilwood Drilled Rotors & 4 Piston Polished Calipers W/ Polished Hubs	BS-020-D-K	605.00
12" Wilwood Drilled Rotors & 4 Piston Polished Calipers W/ Polished Hubs**	DF-209-K	900.00
13" Wilwood Drilled Rotors & 6 Piston Black Calipers W/ Black Hubs**	DF-207-B-K	1,905.00
13" Wilwood Drilled Rotors & 6 Piston Polished Calipers W/ Black Hubs**	DF-207-P-K	1,905.00

**12" or 13" Optional Brake Packages Require Optional Stainless Steel Spindles

SHOCK & SPRING OPTIONS

Description	Part#	Add
350# Springs/Plain Billet Coil-Over Shocks	BS-027-35	Included
400# Springs/Plain Billet Coil-Over Shocks	BS-027-40	Included
450# Springs/Plain Billet Coil-Over Shocks	BS-027-45	Included
500# Springs/Plain Billet Coil-Over Shocks	BS-027-50	Included
600# Springs/Plain Billet Coil-Over Shocks	BS-027-60	Included
350# Springs/Polished Billet Coil-Over Shocks	BS-028-35	86.00
400# Springs/Polished Billet Coil-Over Shocks	BS-028-40	86.00
450# Springs/Polished Billet Coil-Over Shocks	BS-028-45	86.00
500# Springs/Polished Billet Coil-Over Shocks	BS-028-50	86.00
600# Springs/Polished Billet Coil-Over Shocks	BS-028-60	86.00
Thrust Bearings For Coil-Over Shocks	CQ-010	40.00
Spanner Wrench	TA-001	18.00

SPINDLE OPTIONS

Description	Part#	Add
Plain Spindles	BS-007	Included
Polished Stainless Steel Spindles For 12" & 13" Brake Kits	BS-012	275.00
Polished Stainless Steel Spindles W/Aluminum Brackets For 11" Brake Kits	BS-012-S	394.00

RACK & PINION OPTIONS

Description	Part#	Add
Manual Rack & Pinion	BS-004	Included
Manual Rack & Pinion W/Stainless Steel Tie Rod Ends	BS-004-SS	135.00
Billet Manual Rack & Pinion	BS-004-B	767.00
Billet Manual Rack & Pinion W/Stainless Steel Tie Rod Ends	BS-004-B-SS	861.00

ADDITIONAL OPTIONS

Description	Part#	Price
11" Polished Rotor Covers for Stainless Steel Spindles - Must Use BS-012 Spindles	BS-010	324.00
12" Polished Rotor Covers for Stainless Steel Spindles - Must Use BS-012 Spindles	BS-018	305.00
Polished Stainless Steel Tie Rod Ends, Pair	MP-017-SS	132.00
Swaybar	BS-053	292.00
Chrome Swaybar	BS-053-C	476.00
Aluminum Caliper Covers, Pair	DF-056	189.00
16" Braided Stainless Steel Brake Line Kit	BX-055-1	50.00
Polished Stainless Steel Ball Joint Caps, Pair	BS-029	65.00



BS-020



BS-020-D



DF-209-P



BS-010, BS-018



BS-004-B



BS-029



MP-017-SS

HEIDTS® STREET ROD PARTS



Order/Tech: 800-841-8188

HEIDTS SUPERIDE® II



Product is painted for catalog purposes only! All kits ship with Silver Powder Coated Springs - not shown.

INCLUDED IN BASE KIT:

- HEIDTS® Crossmember
- Tubular Upper & Lower Arms, Standard or Narrowed
- Stock Mustang II Spindles
- Manual Rack & Pinion Steering
- 11" Rotors with 4 Piston Wilwood Calipers
- Billet Single Adjustable Coil-Over Shocks with Silver Powder Coated Springs

Now with Silver Powder Coated Springs! Powder coating does not rust or peel while saving you money!

COMPLETE BASE KIT STARTING AT \$3,369

HEIDTS® IFS IS BETTER

Our HEIDTS SUPERIDE® II IFS System is the ultimate front suspension system for fat fendered Ford fans, '35-'40 Ford and '41-48 Fords. Enjoy driving your fat fendered cruiser with the smooth ride and good handling of independent suspension. Add to the value of your car with a HEIDTS® independent suspension system, the most popular suspension system in use today. Why? Because they are engineered right to work right.

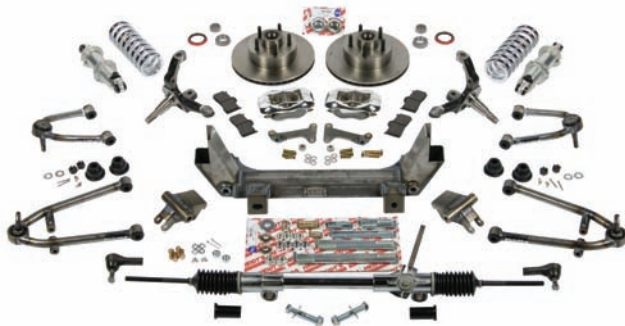

ALL NEW! NOT A MUSTANG CONVERSION KIT!

Our HEIDTS SUPERIDE® II IFS System uses a Mustang II spindle to allow for a front mount rack & pinion unit, this allows for easy engine installation. The upper control arms use threaded adjusters for the wheel alignment. These threaded adjusters, unlike eccentric adjusters, will never "slip" and lose alignment no matter how big a bump you hit. "Smooth" describes the ride: very low and highly steerable with no bumpsteer and built-in anti-dive. Installing the 3-piece cross member is an easy operation. Combined with detailed instructions your installation will be as smooth as your ride with your new HEIDTS SUPERIDE® II from HEIDTS®.



BX-202 '35-'40 Ford Car BX-202 '35-'41 Ford Pick-up BX-203 '41-'48 Ford BX-212 '37-'39 Chevy



BX-213 '40-'48 Chevy BX-305 '40-'46 Chevy Pick-up BX-306 '47-'54 Chevy Pick-up BX-211 '37-'41 Willy's

Final ride height from spindle to bottom of frame:

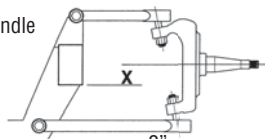

- '35-'48 Ford 2"
- '37-'41 Willy's 2"
- '37-'48 Chevy 2"
- '40-'46 Chevy Pick-up 2-13/16"
- '47-'54 Chevy Pick-up 2-13/16"

* (Stock spindles may be substituted to raise vehicle 2".)

COMPLETE BASE KIT

Description	Part#	Base Price
35-40 Ford + 35-41 Ford Pick-Up	BX-202	3,369.00
41-48 Ford	BX-203	3,369.00
37-41 Willys	BX-211	3,369.00
37-41 Willys IDA or Outlaw Chassis	BX-211-N	3,369.00
37-39 Chevy	BX-212	3,369.00
40-48 Chevy	BX-213	3,369.00
40-46 Chevy Pick-Up	BX-305	3,369.00
47-54 Chevy Pick-Up	BX-306	3,369.00

OPTIONS

HEIDTS SUPERIDE® II

Owner: Lonnie & Sharon Keith
Builder: Street Rods by Michael



HEIDTS® STREET ROD PARTS

CONTROL ARM OPTIONS

Description	Part#	Add
Tubular Arms	BS-025	Included
Stainless Steel Tubular Arms	BS-026	1,345.00

BRAKE OPTIONS

Description	Part#	Add
11" Iron Rotors & 4 Piston Black or Polished Calipers	DF-202-C-B or C-P	Included
12" Wilwood Drilled Rotors & 4 Piston Black, Polished Calipers	DF-208-P-K	686.00
13" Wilwood Drilled Rotors & 6 Piston Black, Polished Calipers	DF-206-P-K	1,734.00

Additional options available. Call for pricing.

SPINDLE OPTIONS

Description	Part#	Add
Stock Spindles	MP-028	Included
2" Dropped Spindles	SP-101-K	Included

RACK & PINION OPTIONS

Description	Part#	Add
Manual Rack & Pinion	MP-018-I-K	Included
Power Rack & Pinion	MP-038-3-K	140.00
Power Rack W/ Stainless Steel Tie Rod Ends	MP-038-SS-K	275.00

SHOCK & SPRING OPTIONS

Description	Part#	Add
400#, 450#, 500#, 550# Springs/Plain Billet Coil-Over Shocks	BS-001-XX	Included
400#, 450#, 500#, 550# Springs/Polished Billet Coil-Over Shocks	BS-002-XX	86.00
Thrust Bearings For Coil-Over Shocks	CQ-010	40.00
Spanner Wrench	TA-001	18.00

ADDITIONAL OPTIONS

Description	Part#	Price
Swaybar	BS-056	189.00
Narrowed Swaybar	BS-056-N	189.00
Chrome Swaybar	BS-056-C	470.00
Narrowed Chrome Swaybar	BS-056-C-N	470.00
Polished Stainless Steel Ball Joint Caps, Pair	MP-034	66.00
14" Braided Stainless Steel Brake Line Kit	BX-055	39.00

BS-026



DF-202-P-K



DF-202-D-P-K



DF-208-P-K



DF-206-B-K



SP-101-K



MP-038-3-K



BX-055

MP-035



Order/Tech: 800-841-8188

CLASSIC TRUCKS

HEIDTS SUPERIDE® II



Product is painted for catalog purposes only! All kits ship with Silver Powder Coated Springs - not shown.

THE BEST RIDE IN TOWN FOR CLASSIC TRUCKS - AVAILABLE FOR: '55-'59 CHEVY, '53-'64 FORD

INCLUDED IN BASE KIT:

- HEIDTS® Crossmember
- Stock or Dropped Mustang II Spindles
- Tubular Upper & Lower Arms, Standard or Narrowed
- Manual Rack & Pinion Steering
- 11" Rotors with 4 Piston Wilwood Calipers
- Billet Single Adjustable Coil-Over Shocks with Silver Powder Coated Springs

Now with Silver Powder Coated Springs! Powder coating does not rust or peel while saving you money!

COMPLETE BASE KIT STARTING AT \$3,440

HEIDTS® IFS IS BETTER

Our HEIDTS SUPERIDE® II IFS System is the ultimate front suspension system. Enjoy driving with the smooth ride and good handling of independent suspension, and add to the value of your classic truck with a HEIDTS® independent suspension system, the most popular suspension system in use today. Why? Because they are engineered right to work right!

ALL NEW! NOT A MUSTANG CONVERSION KIT!

Our HEIDTS SUPERIDE® II IFS System uses a Mustang II spindle to allow for a front mount rack & pinion unit, this allows for easy engine installation. The upper control arms use threaded adjusters for the wheel alignment. These threaded adjusters, unlike eccentric adjusters, will never "slip" and lose ride alignment no matter how big a bump you hit. "Smooth" describes the ride: very low and highly steerable with no bumpsteer and built-in anti-dive. Installing the 3-piece cross member is an easy operation. Combined with detailed instructions your installation will be as smooth as your ride with your new HEIDTS SUPERIDE® II from HEIDTS®.

COMPLETE BASE KIT

Description	Part#	Base Price
55-59 Chevy Pick-Up	BX-307	3,440.00
48-52 Ford Pick-Up	BX-310	3,440.00
53-64 Ford Pick-Up	BX-316	3,440.00

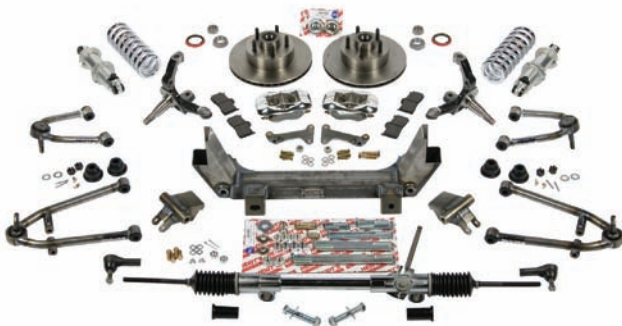

Final ride height from spindle to bottom of frame:

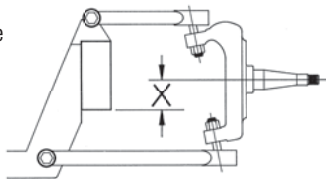

'55-'59 Chevy Pick-Up 2-1/2" *
'53-'56 Ford Pick-Up 0

*Stock spindles may be substituted to raise vehicle 2".



BX-316 '53-'56 Ford F-100



BX-307 '55-'59 Chevy Pick-Up

OPTIONS

HEIDTS SUPERIDE® II

Custom Classics
Island Lake, Illinois



CONTROL ARM OPTIONS

Description	Part#	Add
Tubular Arms (Narrowed available)	BS-021-RS	Included
Stainless Steel Tubular Arms (NA)	BS-022-RS	1,291.00

BRAKE OPTIONS

Description	Part#	Add
11" Iron Rotors & 4 Piston Black or Polished Calipers	DF-202-C-B or C-Pl	Included
12" Wilwood Drilled Rotors & 4 Piston Black, Calipers	DF-208-B-K	686.00
13" Wilwood Drilled Rotors & 6 Piston Black, Calipers	DF-206-B-K	1,734.00

Additional options available. Call for pricing.

SPINDLE OPTIONS

Description	Part#	Add
Stock Spindles (Standard on BX-316, Option on BX-307)	MP-028	Included
2" Dropped Spindles (Standard on BX-307, Option on BX-316)	SP-101-K	Included

RACK & PINION OPTIONS

Description	Part#	Add
Manual Rack & Pinion	MP-018-1-K-CT	Included
Chrome Manual Rack	MP-018-C-K-CT	254.00
Power Rack	MP-038-3-K-CT	140.00
Chrome Power Rack	MP-038-C-K-CT	463.00

SHOCK & SPRING OPTIONS

Description	Part#	Add
400#, 450#, 500#, 550# Springs/Plain Billet Coil-Over Shocks	BS-003-XX	Included
Thrust Bearings For Coil-Over Shocks	CQ-010	40.00
Spanner Wrench	TA-001	18.00

ADDITIONAL OPTIONS

Description	Part#	Price
Swaybar	BS-054-RS	215.00
Chrome Swaybar	BS-054-C-RS	443.00
Polished Stainless Steel Ball Joint Caps, Pair	MP-035	66.00
14" Braided Stainless Steel Brake Line Kit	BX-055	39.00



BS-022-RS

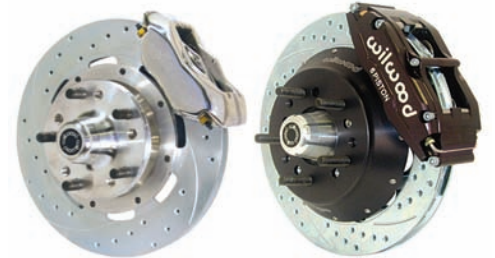

BS-054-C



MP-035



BX-055



Order/Tech: 800-841-8188

'65-'72 FORD F-100 HEAVY DUTY FRONT SUBFRAME

NEW! BOLT-IN FULL FRONT SUSPENSION



Product is painted for catalog purposes only! All kits ship with Silver Powder Coated Springs - not shown.

INCLUDED IN BASE KIT:

- 1-1/4" Upper Tubular Control Arms & 1-1/2" Lower Tubular Control Arms
- 11" Disc Brakes with Wilwood 4-Piston Calipers
- Choice of Stock or Dropped Mustang II Spindles
- Power Rack & Pinion
- Bolt-On 3x4 Crossmember made out of 7GA with an Internal Gusset for added strength
- Adjustable Billet Shocks and Silver Powder Coated Springs

Now with Silver Powder Coated Springs! Powder coating does not rust or peel while saving you money!

**COMPLETE BASE KIT
STARTING AT \$3,672**

COMPLETE BASE KIT

Description	Part#	Base Price
65-72 F100 Superide II	BX-640	3,672.00

CONTROL ARM OPTIONS

Description	Part#	Add
1-1/4" Upper and 1-1/2" Lower Tubular Arm Kit	BS-081	Included

BRAKE OPTIONS

Description	Part#	Add
11" Iron Rotors, Wilwood 4 Piston Black Calipers, Chevy Bolt	DF-202-C-B-K	Included
11" Iron Rotors, Wilwood 4 Piston Pol. Calipers, Chevy Bolt	DF-202-C-P-K	Included
11" Iron Rotors, Wilwood 4 Piston Red Calipers, Chevy Bolt	DF-202-C-RED-K	Included
11" Iron Rotors, Wilwood 4 Piston Black Calipers, Ford Bolt	DF-202-F-B-K	Included
11" Iron Rotors, Wilwood 4 Piston Polished Calipers, Ford Bolt	DF-202-F-P-K	Included
11" Iron Rotors, Wilwood 4 Piston Red Calipers, Ford Bolt	DF-202-F-RED-K	Included
11" Wilwood Smooth Rotors & 4 Piston Black Calipers	DF-202-B-K01	427.00
11" Wilwood Smooth Rotors & 4 Piston Polished Calipers	DF-202-P-K01	427.00
11" Wilwood Smooth Rotors & 4 Piston Red Calipers	DF-202-RED-K01	427.00
11" Wilwood Drilled Rotors & 4 Piston Black Calipers	DF-202-D-B-K01	594.00
11" Wilwood Drilled Rotors & 4 Piston Polished Calipers	DF-202-D-P-K01	594.00
11" Wilwood Drilled Rotors & 4 Piston Red Calipers	DF-202-D-RED-K01	594.00
12" Wilwood Drilled Rotors & 4 Piston Black Calipers	DF-208-B-K01	686.00
12" Wilwood Drilled Rotors & 4 Piston Polished Calipers	DF-208-P-K01	686.00
12" Wilwood Drilled Rotors & 4 Piston Red Calipers	DF-208-RED-K01	686.00
13" Wilwood Drilled Rotors & 6 Piston Black Calipers	DF-206-B-K01	1,734.00
13" Wilwood Drilled Rotors & 6 Piston Polished Calipers	DF-206-P-K01	1,734.00
13" Wilwood Drilled Rotors & 6 Piston Red Calipers	DF-206-RED-K01	1,734.00

SPINDLE OPTIONS

Description	Part#	Add
Stock Spindles	MP-028-K	Included
2" Dropped Spindles	SP-101-K	Included

RACK & PINION OPTIONS

Description	Part#	Add
Power Rack & Pinion 20:1 ratio, 3 turn lock to lock	ST-002-K	Included

SHOCK & SPRING OPTIONS

Description	Part#	Add
Plain Billet single adj. shock 15-3/8" ext - 11-1/2" comp.	CB-105-G	Included
350# Silver Powder Coated 10" Spring	CS-350-10-K	Included
400# Silver Powder Coated 10" Spring	CS-400-10-K	Included
450# Silver Powder Coated 10" Spring	CS-450-10-K	Included
500# Silver Powder Coated 10" Spring	CS-500-10-K	Included
550# Silver Powder Coated 10" Spring	CS-550-10-K	Included
600# Silver Powder Coated 10" Spring	CS-600-10-K	Included

ADDITIONAL OPTIONS

Description	Part#	Price
Motor Mount Stands for SBC, BBC, and LS.	CF-104	213.00
Urethane LS adapter Kit	MM-200	163.00
1" Solid Front Sway Bar with hardware	SB-213	250.00
Universal Transmission Cross Member	BX-603	88.00
Steering hook up kit for power rack to IDIDIT Column	SC-311	335.00
IDIDIT Paintable, Tilt, Floor shift w/ 3/4"-36 spline shaft	1120657010	486.00
IDIDIT Black Powder coat, Tilt, Floor shift w/ 3/4"-36 spline shaft	1120657051	630.00
IDIDIT Paintable, Tilt, Floor shift w/ 3/4"-36 spline shaft	1120657020	630.00
IDIDIT Paintable, Tilt, Column shift w/ 3/4"-36 spline shaft	1140657010	783.00
IDIDIT Black Powder coat, Tilt, Column shift w/ 3/4"-36 spline shaft	1140657051	1,001.00
IDIDIT Chrome, Tilt, Column shift w/ 3/4"-36 spline shaft	1140657020	1,001.00

'65-'72 FORD F-100 HEAVY DUTY REAR 4-LINK

NEW! BOLT-IN HEAVY DUTY 4-LINK

COMPLETE BASE KIT STARTING AT \$3,111

Product is painted for catalog purposes only! All kits ship with Silver Powder Coated Springs - not shown.

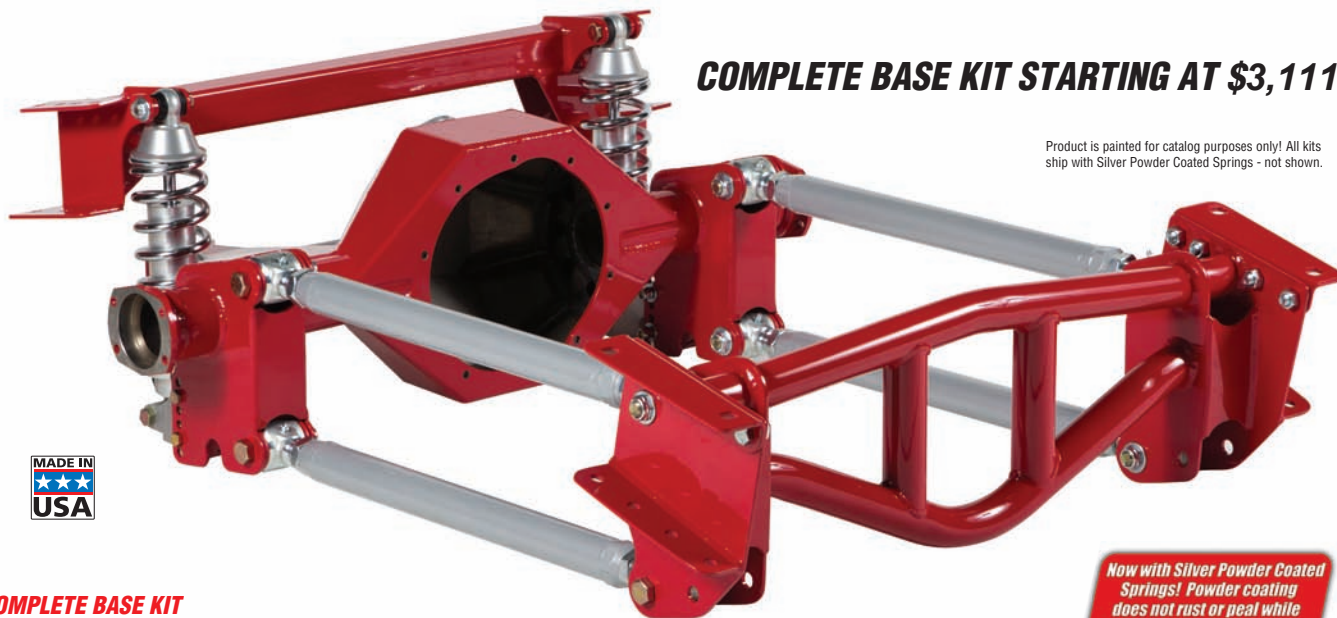

COMPLETE BASE KIT

Description	Part#	Base Price
66-72 F-100 Rear 4-Link with Axle Brackets	RB-113	3,111.00
66-72 F-100 Rear 4-Link less Axle Brackets (use if ordering our housing)	RB-113-H	3,111.00

SHOCK OPTION

Description	Part#	Add
Billet Adjustable Shock - 15-3/8" ext. 10-3/8" comp.	CB-105-G	Included

SPRING OPTIONS

Description	Part#	Add
Billet Adjustable Shock - 15-3/8" ext. 10-3/8" comp.	CR-180-11-B	Included
Billet Adjustable Shock - 15-3/8" ext. 10-3/8" comp.	CR-200-11-B	Included
Billet Adjustable Shock - 15-3/8" ext. 10-3/8" comp.	CR-250-11-B	Included
Billet Adjustable Shock - 15-3/8" ext. 10-3/8" comp.	CR-300-11-B	Included
Billet Adjustable Shock - 15-3/8" ext. 10-3/8" comp.	CR-350-11-B	Included
Billet Adjustable Shock - 15-3/8" ext. 10-3/8" comp.	CR-400-11-B	Included
Billet Adjustable Shock - 15-3/8" ext. 10-3/8" comp.	CR-180-11-C	Included
Billet Adjustable Shock - 15-3/8" ext. 10-3/8" comp.	CR-200-11-C	Included
Billet Adjustable Shock - 15-3/8" ext. 10-3/8" comp.	CR-250-11-C	Included
Billet Adjustable Shock - 15-3/8" ext. 10-3/8" comp.	CR-300-11-C	Included
Billet Adjustable Shock - 15-3/8" ext. 10-3/8" comp.	CR-350-11-C	Included
Billet Adjustable Shock - 15-3/8" ext. 10-3/8" comp.	CR-400-11-C	Included

3RD MEMBER OPTIONS

Description	Part#	Price
Positraction 31 Spline 3.00 Ratio	BN-300-I-L	1,333.00
Positraction 31 Spline 3.25 Ratio	BN-325-I-L	1,333.00
Positraction 31 Spline 3.50 Ratio	BN-350-I-L	1,333.00
Positraction 31 Spline 3.70 Ratio	BN-370-I-L	1,333.00
Positraction 31 Spline 3.90 Ratio	BN-390-I-L	1,333.00
Positraction 31 Spline 4.11 Ratio	BN-411-I-L	1,333.00

4-LINK FEATURES:

- 64 inch track width
 - Double adjustable link Tubes (1.75 inch 120 DOM)*
 - Rods Ends are 1 Inch (largest in Industry)*
 - Optional Fabricated (Star Wars) housing *
 - Adjustable ride Height*
 - Adjustable 3 position Pan Hard Bar*
 - Billet Aluminium Shock Mounts *
 - Built in Drive shaft Loop
- * Industry Exclusive

Now with Silver Powder Coated Springs! Powder coating does not rust or peel while saving you money!

REAR AXLE HOUSING W/ BRACKETS INSTALLED

Description	Part#	Price
64" Track Housing with brackets welded on	RF-040-64-H	810.00
64" Track Fab. Housing with brackets welded on	FH-064-113	1,064.00

REAR AXLES 31 SPLINE

Description	Part#	Price
64" Track 31 Spline Axles, pr.	RC-041-64-31	647.00

BRAKE OPTIONS

Description	Part#	Price
11" Heavy Duty Drum Brake	RN-054	630.00
12" Iron Rotors, GM Single Piston Calipers With Parking Brake	DR-005-E-P	753.00
12" Wilwood Smooth Rotors & 4 Piston Black Calipers W/Parking Brake	DR-005-P-B	766.00
12" Wilwood Smooth Rotors & 4 Piston Red Calipers W/Parking Brake	DR-005-P-RED	861.00
12" Wilwood Smooth Rotors & 4 Piston Pol. Calipers W/Parking Brake	DR-005-P	842.00
12" Wilwood Drilled Rotors & 4 Piston Black Calipers W/Parking Brake	DR-005-P-D-B	845.00
12" Wilwood Drilled Rotors & 4 Piston Red Calipers W/Parking Brake	DR-005-P-D-RED	945.00
12" Wilwood Drilled Rotors & 4 Piston Pol. Calipers W/Parking Brake	DR-005-P-D	958.00



Order/Tech: 800-841-8188

'67-'87 CHEVY C-10 HEAVY DUTY FRONT SUBFRAME



NEW! BOLT-IN FULL FRONT SUSPENSION



Product is painted for catalog purposes only! All kits ship with Silver Powder Coated Springs - not shown.

INCLUDED IN BASE KIT:

- 1-1/4" Upper Tubular Control Arms & 1-1/2" Lower Tubular Control Arms
- 11" Disc Brakes with Wilwood 4-Piston Calipers
- Choice of Stock or Dropped Mustang II Spindles
- Power Rack & Pinion
- Bolt-On 3x4 Crossmember made out of 7GA with an Internal Gusset for added strength
- Adjustable Billet Shocks and Silver Powder Coated Springs

Now with Silver Powder Coated Springs! Powder coating does not rust or peel while saving you money!

**COMPLETE BASE KIT
STARTING AT \$3,672**

COMPLETE BASE KIT

Description	Part#	Base Price
67-72 C-10 Heavy Duty Front	BX-603	3,672.00
73-87 C-10 Heavy Duty Front	BX-660	3,672.00

CONTROL ARM OPTIONS

Description	Part#	Add
1-1/4" Upper and 1-1/2" Lower Tubular Arm Kit	BS-081	Included

BRAKE OPTIONS

Description	Part#	Add
11" Iron Rotors, Wilwood 4 Piston Black Calipers, Chevy Bolt	DF-202-C-B-K	Included
11" Iron Rotors, Wilwood 4 Piston Pol. Calipers, Chevy Bolt	DF-202-C-P-K	Included
11" Iron Rotors, Wilwood 4 Piston Red Calipers, Chevy Bolt	DF-202-C-RED-K	Included
11" Iron Rotors, Wilwood 4 Piston Black Calipers, Ford Bolt	DF-202-F-B-K	Included
11" Iron Rotors, Wilwood 4 Piston Polished Calipers, Ford Bolt	DF-202-F-P-K	Included
11" Iron Rotors, Wilwood 4 Piston Red Calipers, Ford Bolt	DF-202-F-RED-K	Included
11" Wilwood Smooth Rotors & 4 Piston Black Calipers	DF-202-B-K01	427.00
11" Wilwood Smooth Rotors & 4 Piston Polished Calipers	DF-202-P-K01	427.00
11" Wilwood Smooth Rotors & 4 Piston Red Calipers	DF-202-RED-K01	427.00
11" Wilwood Drilled Rotors & 4 Piston Black Calipers	DF-202-D-B-K01	594.00
11" Wilwood Drilled Rotors & 4 Piston Polished Calipers	DF-202-D-P-K01	594.00
11" Wilwood Drilled Rotors & 4 Piston Red Calipers	DF-202-D-RED-K01	594.00
12" Wilwood Drilled Rotors & 4 Piston Black Calipers	DF-208-B-K01	686.00
12" Wilwood Drilled Rotors & 4 Piston Polished Calipers	DF-208-P-K01	686.00
12" Wilwood Drilled Rotors & 4 Piston Red Calipers	DF-208-RED-K01	686.00
13" Wilwood Drilled Rotors & 6 Piston Black Calipers	DF-206-B-K01	1,734.00
13" Wilwood Drilled Rotors & 6 Piston Polished Calipers	DF-206-P-K01	1,734.00
13" Wilwood Drilled Rotors & 6 Piston Red Calipers	DF-206-RED-K01	1,734.00

SPINDLE OPTIONS

Description	Part#	Add
Stock Spindles	MP-028-K	Included
2" Dropped Spindles	SP-101-K	Included

RACK & PINION OPTIONS

Description	Part#	Add
Power Rack & Pinion 20:1 ratio, 3 turn lock to lock	ST-002-K	Included

SHOCK & SPRING OPTIONS

Description	Part#	Add
Plain Billet single adj. shock 15-3/8" ext - 11-1/2" comp.	CB-105-G	Included
350# Silver Powder Coated 10" Spring	CS-350-10-K	Included
400# Silver Powder Coated 10" Spring	CS-400-10-K	Included
450# Silver Powder Coated 10" Spring	CS-450-10-K	Included
500# Silver Powder Coated 10" Spring	CS-500-10-K	Included
550# Silver Powder Coated 10" Spring	CS-550-10-K	Included
600# Silver Powder Coated 10" Spring	CS-600-10-K	Included

ADDITIONAL OPTIONS

Description	Part#	Price
Motor Mount Stands for SBC, BBC, and LS.	MM-70	99.00
Urethane LS adapter Kit	MM-200	163.00
1" Solid Front Sway Bar with hardware	SB-213	250.00
Universal Transmission Cross Member	BX-603	87.00
Steering hook up kit for power rack to IDIDIT Column	SC-311	335.00

'67-'87 CHEVY C-10 HEAVY DUTY REAR 4-LINK



NEW! BOLT-IN HEAVY DUTY 4-LINK

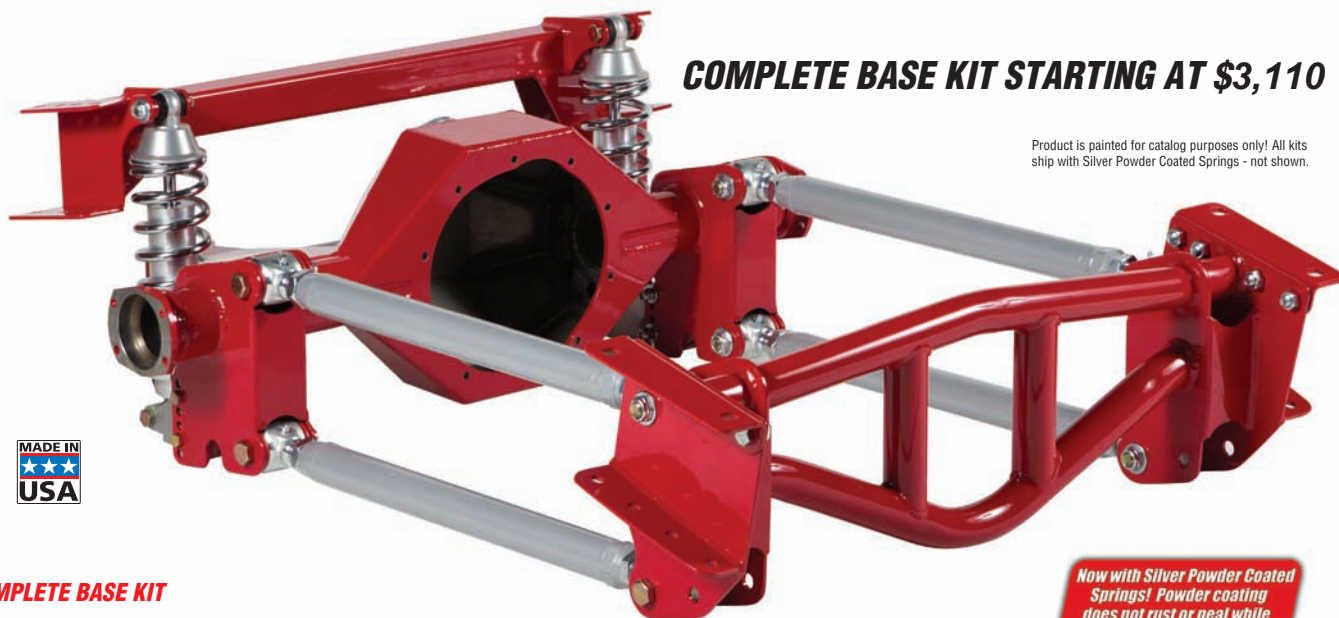

COMPLETE BASE KIT STARTING AT \$3,110

Product is painted for catalog purposes only! All kits ship with Silver Powder Coated Springs - not shown.



COMPLETE BASE KIT

Description	Part#	Base Price
67-72 C-10 Rear 4-Link with Axle Brackets	RB-112	3,110.00
67-72 C-10 Rear 4-Link less Axle Brackets (use if ordering our housing)	RB-112-H	3,110.00
73-87 Chevy C-10 Heavy Duty Rear	RB-114	3,110.00

SHOCK OPTION

Description	Part#	Add
Billet Adjustable Shock - 15-3/8" ext. 10-3/8" comp.	CB-105-G	Included

SPRING OPTIONS

Description	Part#	Add
Billet Adjustable Shock - 15-3/8" ext. 10-3/8" comp.	CR-180-11-B	Included
Billet Adjustable Shock - 15-3/8" ext. 10-3/8" comp.	CR-200-11-B	Included
Billet Adjustable Shock - 15-3/8" ext. 10-3/8" comp.	CR-250-11-B	Included
Billet Adjustable Shock - 15-3/8" ext. 10-3/8" comp.	CR-300-11-B	Included
Billet Adjustable Shock - 15-3/8" ext. 10-3/8" comp.	CR-350-11-B	Included
Billet Adjustable Shock - 15-3/8" ext. 10-3/8" comp.	CR-400-11-B	Included
Billet Adjustable Shock - 15-3/8" ext. 10-3/8" comp.	CR-180-11-C	Included
Billet Adjustable Shock - 15-3/8" ext. 10-3/8" comp.	CR-200-11-C	Included
Billet Adjustable Shock - 15-3/8" ext. 10-3/8" comp.	CR-250-11-C	Included
Billet Adjustable Shock - 15-3/8" ext. 10-3/8" comp.	CR-300-11-C	Included
Billet Adjustable Shock - 15-3/8" ext. 10-3/8" comp.	CR-350-11-C	Included
Billet Adjustable Shock - 15-3/8" ext. 10-3/8" comp.	CR-400-11-C	Included

3RD MEMBER OPTIONS

Description	Part#	Price
Positraction 31 Spline 3.00 Ratio	BN-300-I-L	1,333.00
Positraction 31 Spline 3.25 Ratio	BN-325-I-L	1,333.00
Positraction 31 Spline 3.50 Ratio	BN-350-I-L	1,333.00
Positraction 31 Spline 3.70 Ratio	BN-370-I-L	1,333.00
Positraction 31 Spline 3.90 Ratio	BN-390-I-L	1,333.00
Positraction 31 Spline 4.11 Ratio	BN-411-I-L	1,333.00

4-LINK FEATURES:

- 64 inch track width
- Double adjustable link Tubes (1.75 inch 120 DOM)*
- Rods Ends are 1 Inch (largest in Industry)*
- Optional Fabricated (Star Wars) housing *
- Adjustable ride Height*
- Adjustable 3 position Pan Hard Bar*
- Billet Aluminium Shock Mounts *
- Built in Drive shaft Loop
- * Industry Exclusive

Now with Silver Powder Coated Springs! Powder coating does not rust or peel while saving you money!

REAR AXLE HOUSING W/ BRACKETS INSTALLED

Description	Part#	Price
64" Track Housing with brackets welded on	RC-040-64-H	810.00
64" Track Fab. Housing with brackets welded on	FH-064-112	1064.00

REAR AXLES 31 SPLINE

Description	Part#	Price
64" Track 31 Spline Axles, pr.	RC-041-64-31	647.00

BRAKE OPTIONS

Description	Part#	Price
11" Heavy Duty Drum Brake	RN-054	630.00
12" Iron Rotors, GM Single Piston Calipers With Parking Brake	DR-005-E-P	753.00
12" Wilwood Smooth Rotors & 4 Piston Black Calipers W/Parking Brake	DR-005-P-B	766.00
12" Wilwood Smooth Rotors & 4 Piston Red Calipers W/Parking Brake	DR-005-P-RED	861.00
12" Wilwood Smooth Rotors & 4 Piston Pol. Calipers W/Parking Brake	DR-005-P	842.00
12" Wilwood Drilled Rotors & 4 Piston Black Calipers W/Parking Brake	DR-005-P-D-B	845.00
12" Wilwood Drilled Rotors & 4 Piston Red Calipers W/Parking Brake	DR-005-P-D-RED	945.00
12" Wilwood Drilled Rotors & 4 Piston Pol. Calipers W/Parking Brake	DR-005-P-D	958.00



Order/Tech: 800-841-8188

HEIDTTS® STREET ROD PARTS

REAR 4-LINK KITS

Now with Silver Powder Coated Springs! Powder coating does not rust or peel while saving you money!

RB-108-SS

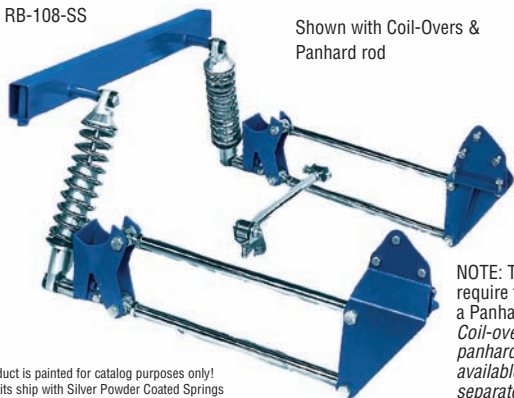

Shown with Coil-Overs & Panhard rod

NOTE: These kits require the use of a Panhard Rod. Coil-overs and panhard rod are available separately.

Product is painted for catalog purposes only! All kits ship with Silver Powder Coated Springs - not shown.

CLASSIC TRUCK 4-LINK KITS

Coil-over, 4-Link rear suspension provides the best ride for any classic truck. These kits attach directly to the stock frame rails. The adjustable axle brackets let you set ride height in one of three positions. A bolt-in upper crossmember for coil-overs is included. Kits available in plain steel or with polished stainless steel.

Description	Part#	Price
47-53 Chevy Pick-Up - Plain Bars	RB-108	686.00
47-53 Chevy Pick-Up - Polished Stainless Steel Bars	RB-108-SS	1,426.00
54-55 Chevy Pick-Up (1st Series) - Plain Bars	RB-109	686.00
54-55 Chevy Pick-Up (1st Series) - Polished Stainless Steel Bars	RB-109-SS	1,426.00
55-59 Chevy Pick-Up (2nd Series) - Plain Bars	RB-110	686.00
55-59 Chevy Pick-Up (2nd Series) - Polished Stainless Steel Bars	RB-110-SS	1,426.00
53-54 Ford F100 - Plain Bars	RB-120	686.00
53-54 Ford F100 - Polished Stainless Steel Bars	RB-120-SS	1,426.00
55-56 Ford F100 - Plain Bars	RB-121	686.00
55-56 Ford F100 - Polished Stainless Steel Bars	RB-121-SS	1,426.00

RB-201-SS

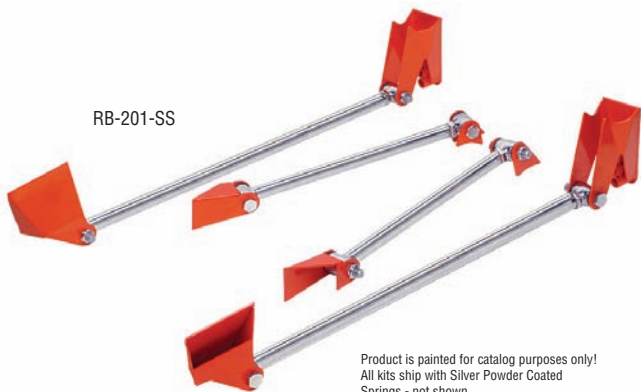

Product is painted for catalog purposes only! All kits ship with Silver Powder Coated Springs - not shown.

STREET ROD TRIANGULATED 4-LINK KITS

Triangulated 4-Link Kits are very popular as they do not require a Panhard Rod. This design is also similar to many GM installations. Bars are fully adjustable, 1" X .156 tube with 3/4" stainless adjusters and urethane bushings, angled and straight chassis brackets, multi-position coil-over axle brackets, tabs and hardware. These kits are available in plain steel or polished stainless steel tubes.

Description	Part#	Price
Model A - Plain	RB-201	559.00
Model A - Polished Stainless Steel	RB-201-SS	1,056.00
32 Ford - Plain	RB-202	559.00
32 Ford - Polished Stainless Steel	RB-202-SS	1,056.00
33-34 Ford - Plain	RB-203	559.00
33-34 Ford - Polished Stainless Steel	RB-203-SS	1,056.00
Universal Triangulated 4-Link Kit	RB-201-U	706.00

RB-101-SS



Product is painted for catalog purposes only! All kits ship with Silver Powder Coated Springs - not shown.

STREET ROD PARALLEL 4-LINK KITS

The Parallel 4-Link Kit is very easy to install and is a good choice for many installations. It uses 1" X .156 tube bars with 3/4" stainless adjusters and urethane bushings, chassis mounting brackets, multi-position coil-over axle brackets and hardware. NOTE: These kits require the use of a Panhard Rod. Intended for fully boxed or aftermarket frames.

Description	Part#	Price
Model A - Plain	RB-101	559.00
Model A - Polished Stainless Steel	RB-101-SS	1,060.00
32-34 Ford - Plain	RB-102	559.00
32-34 Ford - Polished Stainless Steel	RB-102-SS	1,056.00

REAR 4-LINK KITS

Owner: Scott Diedrich
Builder: Custom
Classics



HEIDTS® COMPONENTS

STREET ROD PANHARD RODS

Description	Part#	Price
Universal Plain Weld-On	RP-101	107.00
Universal Polished Stainless Steel Weld-On	RP-101-SS	323.00
Universal Plain Bolt-On**	RP-102	107.00
Universal Polished Stainless Steel Bolt-On**	RP-102-SS	323.00
Model A - Plain	RP-111	107.00
Model A - Polished Stainless Steel	RP-111-SS	323.00
Model A - Plain Uncentered Housing	RP-111-UN	107.00
Model A - Polished Stainless Steel Uncentered Housing	RP-111-SS-UN	323.00
32 Ford - Plain	RP-112	107.00
32 Ford - Polished Stainless Steel	RP-112-SS	323.00
32 Ford - Plain Uncentered Housing	RP-112-UN	107.00
32 Ford - Polished Stainless Steel Uncentered Housing	RP-112-SS-UN	323.00
33-40 Ford - Plain	RP-113	107.00
33-40 Ford - Polished Stainless Steel	RP-113-SS	323.00
33-40 Ford - Plain Uncentered Housing	RP-113-UN	107.00
33-40 Ford - Polished Stainless Steel Uncentered Housing	RP-113-SS-UN	323.00

**Bolt-On Kits For 8" and 9" Ford Housings Only

CLASSIC TRUCK PANHARD RODS

Description	Part#	Price
All Classic Trucks EXCEPT 47-54 Chevy Pick-Up		
Bolt-On Plain Panhard Bar Package**	RP-103	107.00
Bolt-On Polished Stainless Steel Panhard Bar Package**	RP-103-SS	323.00
Weld-On Plain Panhard Bar Package	RP-104	107.00
Weld-On Polished Stainless Steel Panhard Bar Package	RP-104-SS	323.00
47-54 Chevy Pick-Up ONLY		
Bolt-On Plain Panhard Bar Package**	RP-105	107.00
Bolt-On Polished Stainless Steel Panhard Bar Package**	RP-105-SS	323.00
Weld-On Plain Panhard Bar Package	RP-106	107.00
Weld-On Polished Stainless Steel Panhard Bar Package	RP-106-SS	323.00

**Bolt-On Kits For 8" and 9" Ford Housings Only.

COIL-OVER HARDWARE KITS

Use these hardware kits to install your Coil-Overs properly. Kit contains upper bolts, lower bolts, washers, nylon lock nuts and spacers. Available in both plain and polished stainless finish.

Description	Part#	Price
Model A - Plain	HK-048	39.00
Model A - Polished Stainless Steel	HK-048-P	135.00
32-40 Ford - Plain	HK-049	39.00
32-40 Ford - Polished Stainless Steel	HK-049-P	135.00

COIL-OVER CROSSMEMBERS

HEIDTS® also offers Coil-Over Upper Mounts and Coil-Over Crossmembers. The Upper Mounts are for Model A chassis, and Crossmembers are available for '32, '33-'34 and '35-'40 Fords.

Description	Part#	Price
Model A Upper Mounts	RB-051	81.00
'32 to '40 Ford Crossmembers	RB-052	108.00

COIL-OVER SHOCKS

Description	Part#	Price
Plain Billet Rear Coil-Over Shocks	CB-105	448.00
Polished Billet Rear Coil-Over Shocks	CB-105-P	513.00

SPRINGS

Description	Part#	Price
250# Silver Powder Coated 11" Coil Springs	CR-250-11-C	135.00
300# Silver Powder Coated 11" Coil Springs	CR-300-11-C	135.00
350# Silver Powder Coated 11" Coil Springs	CR-350-11-C	135.00

A rear Panhard Rod is used to control lateral movement of the rear axle. It must be used when using a parallel 4-Link suspension kit. Bolt-on and weld-on models are available. Bolt-on models for Ford 8" & 9" rears only. Includes axle bracket, bar with stainless adjuster, urethane bushings and frame bracket. These are available with bar in plain steel tube, or polished stainless steel tube. Specify stock or centered housing for bolt-on kit.



RP-101-SS



RP-102-SS



HK-048



RB-052



CB-105



Order/Tech: 800-841-8188

HEIDTS SUPERIDE® COIL-OVER SHOCKS



CO-101

HEIDTS SUPERIDE® REAR COIL-OVER SHOCKS

HEIDTS SUPERIDE® Rear Coil-over Shocks include urethane bushings, threaded lower spring seats, polished top cones and are available painted or Silver Powder Coated. Shocks are 10" compressed and 14-1/2" extended. Black Powder Coated or Silver Powder Coated plated springs in an assortment of progressive spring rates.

Now with Silver Powder Coated Springs! Powder coating does not rust or peel while saving you money!

- Adjustable Ride Height Spring Seats
- Available Painted and Powder Coated
- 5/8" Hard Chrome Shafts
- Urethane Bushings
- Progressive Rate Springs
- Silver Powder Coated Springs & Shock Bodies are also Available

Description	Part#	Price
Black Coil-Over Shocks	CO-101	280.00
250# Black Coil Springs, Pair	CR-250-11-B	98.00
300# Black Coil Springs, Pair	CR-300-11-B	98.00
350# Black Coil Springs, Pair	CR-350-11-B	98.00
250# Silver Powder Coated Coil Springs, Pair	CR-250-11-C	108.00
300# Silver Powder Coated Coil Springs, Pair	CR-300-11-C	108.00
350# Silver Powder Coated Coil Springs, Pair	CR-350-11-C	108.00

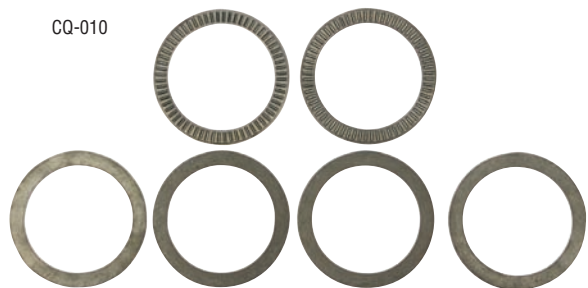

CQ-010

COIL-OVER SHOCK BEARINGS

Make changing the ride height on your vehicle simple with a set of our thrust bearings.

Description	Part#	Price
Thrust Bearing for C/O Shocks	CQ-010	40.00

SPANNER WRENCH

Description	Part#	Price
Adjustable Spanner Wrench	TA-001	18.00
Fitted Spanner Wrench	TA-002	13.00



TA-002



TA-001

HEIDTS SUPERIDE® BILLET COIL-OVER SHOCKS

HEIDTS SUPERIDE® BILLET COIL-OVERS

HEIDTS SUPERIDE® Billet Coil-Over Shock Assemblies are available with plain or polished shock bodies. Springs are Silver Powder Coated on all coil-overs. Spring height adjustment is by a threaded spring seat and locking ring. Shock rate is adjustable using 10 position adjustment knob. Front shocks are 12-3/4" extended, 9-1/2" compressed. Rear shocks are 15-3/8" extended, 10-3/4" compressed. Open wheel shocks are 8-3/4" compressed, 11-3/8" extended.

Now with Silver Powder Coated Springs! Powder coating does not rust or peel while saving you money!

Description	Part#	Price
FRONT		
Plain Front Coil-Over Shocks	CB-101	449.00
Polished Front Coil-Over Shocks	CB-101-P	513.00
400# Silver Powder Coated Coil Springs	CS-400-09	114.00
450# Silver Powder Coated Coil Springs	CS-450-09	114.00
500# Silver Powder Coated Coil Springs	CS-500-09	114.00
550# Silver Powder Coated Coil Springs	CS-550-09	114.00
600# Silver Powder Coated Coil Springs	CS-600-09	114.00
700# Silver Powder Coated Coil Springs	CS-700-09	114.00
REAR		
Plain Rear Coil-Over Shocks	CB-105	449.00
Polished Rear Coil-Over Shocks	CB-105-P	513.00
250# Silver Powder Coated 11" Coil Springs	CR-250-11-C	108.00
300# Silver Powder Coated 11" Coil Springs	CR-300-11-C	108.00
350# Silver Powder Coated 11" Coil Springs	CR-350-11-C	108.00



CB-101

HEIDTS SUPERIDE® BILLET MUSTANG II COIL-OVERS

HEIDTS Superide® Billet Coil-Over Shocks for Mustang II IFS. These shocks provide the highest quality ride characteristics for your Mustang II front end. They are designed for high performance comfort, with increased travel for better ride characteristics. Aluminum body have a bright anodized finish. 5/8" centerless ground solid piston rod, 10 position rebound valving adjuster. Spring height adjustment is by threaded spring seat and locking ring.

Now with Silver Powder Coated Springs! Powder coating does not rust or peel while saving you money!

Description	Part#	Price
HEIDTS® Mustang II Coil-Over Shocks Pr.	MP-050	580.00
HEIDTS® Mustang II Coil-Over Shocks Pr. Polished	MP-050-P	654.00
375# Silver Powder Coated Coil Springs, Pair	MP-041	125.00
500# Silver Powder Coated Coil Springs, Pair	MP-042	125.00
600# Silver Powder Coated Coil Springs, Pair	MP-043	125.00
700# Silver Powder Coated Coil Springs, Pair	MP-044	125.00



MP-050

SPANNER WRENCH

Description	Part#	Price
Adjustable Spanner Wrench	TA-001	18.00
Fitted Spanner Wrench	TA-002	13.00



DISC BRAKES & BRAKE PARTS

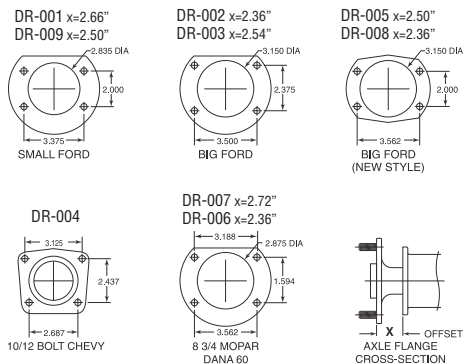

REAR DISC BRAKE KITS

For the ultimate in stopping power and appearance matching the performance of your front brakes. Our deluxe kit includes 12" smooth face .812 thick vented rotors. Also available slotted and crossdrilled. They come complete with four piston calipers, pads, mounting brackets, rotor assemblies, and all hardware. Our economy kits include plain rotors and single piston calipers. All kits include internal drum parking brake.

*****OTHER MANUFACTURER BRAKE KITS AVAILABLE. CALL FOR INFO.**

KITS WITH INTERNAL PARKING BRAKE

Description	Part#	Price
12" Wilwood Smooth Rotors & 4 Piston Polished Calipers With Parking Brake	DR-005-P	842.00
12" Wilwood Smooth Rotors & 4 Piston Black Calipers With Parking Brake	DR-005-P-B	766.00
12" Wilwood Drilled Zinc Rotors & 4 Piston Polished Calipers With Parking Brake	DR-005-P-D	958.00
12" Wilwood Drilled Zinc Rotors & 4 Piston Black Calipers With Parking Brake	DR-005-P-D-B	845.00
12" Iron Rotors & GM Single Piston Calipers With Parking Brake	DR-005-E-P	753.00
12" Wilwood Smooth Rotors & 4 Piston Red Calipers With Parking Brake	DR-005-P-RED	861.00
12" Wilwood Drilled Zinc Rotors & 4 Piston Red Calipers With Parking Brake	DR-005-P-D-RED	945.00



11" Disc Brake Conversion Kit

DF-201-C
DF-201-F

These kits use the 11" rotors with a variety of caliper combinations. Kits are available as a bracket kit only or as a complete kit including calipers and rotors.

MUSTANG II DISC BRAKE CONVERSION KITS

Description	Part#	Price
Chevy Bolt Pattern Complete 11" Disc Brake Kit	DF-201-B-G	395.00
Ford Bolt Pattern Caliper Bracket Kit	DF-101-F	114.00
Ford Bolt Pattern Complete 11" Disc Brake Kit	DF-201-F-G	395.00
5 Bolt Circle Complete Disc Brake Kit	DF-201-5	416.00
5 1/2 Bolt Circle Complete Disc Brake Kit (must be sold with DF-5.5A)	DF-201-5.5	999.00
4 Piston Caliper Bracket Kit	DF-102	92.00
4 Piston Caliper Complete Disc Brake Kit*	DF-202	632.00

*Please specify bolt pattern.



9 1/4" 5 Lug Rotors

MP-010

MP-008
MP-009

9 1/4 MUSTANG II ROTORS - 5 LUG

Convert your rod to 5-bolt pattern wheels the safe and easy way. For '74-'78 Mustang II factory suspensions.

- Direct replacement – no adapters required
- Uses standard Mustang II bearings and seals

Description	Part#	Price
Chevy Bolt Pattern Rotors	MP-008	92.00
Ford Bolt Pattern Rotors	MP-009	92.00
Bearing and Seal Kit	MP-010	31.00

HEIDTS® CARRIES A FULL LINE OF REPLACEMENT BRAKE PADS.

DISC BRAKES & BRAKE PARTS

11" 4 PISTON MUSTANG II BRAKES

11" Billet Brake Kit includes Wilwood 4 Piston Calipers and Plain or Crossdrilled & Slotted Rotors.

Description	Part#	Price
11" Wilwood Smooth Rotors & 4 Piston Black Calipers	DF-202-B	897.00
11" Wilwood Smooth Rotors & 4 Piston Polished Calipers	DF-202-P	897.00
11" Wilwood Smooth Rotors & 4 Piston Red Calipers	DF-202-R	897.00
11" Wilwood Zinc Drilled Rotors & 4 Piston Black Calipers	DF-202-D-B	1,124.00
11" Wilwood Zinc Drilled Rotors & 4 Piston Polished Calipers	DF-202-D-P	1,124.00
11" Wilwood Zinc Drilled Rotors & 4 Piston Red Calipers	DF-202-D-R	1,124.00



DF-202-P



DF-202-D-P

12" 4 PISTON MUSTANG II BIG BRAKES

12" Big Brake Kit with Wilwood Billet 4 Piston Calipers, Polished Aluminum Hubs with Crossdrilled & Slotted Rotors.

Description	Part#	Price
12" Wilwood Drilled Rotors & 4 Piston Black Calipers	DF-208-B	1,117.00
12" Wilwood Drilled Rotors & 4 Piston Polished Calipers	DF-208-P	1,127.00
12" Wilwood Drilled Rotors & 4 Piston Red Calipers	DF-208-R	1,136.00



12" 4 Piston Big Brake Kit
DF-208-P



13" 6 Piston Big Brake Kit
DF-206

13" 6 PISTON MUSTANG II BIG BRAKES

Have the biggest brakes in town! HEIDTS® offers the Wilwood 6 piston calipers installed on huge 13" directional vented rotors.

Description	Part#	Price
13" Wilwood Drilled Rotors & 6 Piston Black Calipers	DF-206-B	2,094.00
13" Wilwood Drilled Rotors & 6 Piston Polished Calipers	DF-206-P	2,227.00
13" Wilwood Drilled Rotors & 6 Piston Red Calipers	DF-206-RED	2,249.00

BRAKE CALIPERS

Billet Aluminum Calipers are available separately. Calipers are four piston type, for .875 thick rotors. They come complete with pads and are ready to install.

Description	Part#	Price
Black Caliper With Pads, Each	DF-049-B	195.00
Red Caliper With Pads, Each	DF-049-R	211.00
Smooth Polished Caliper With Pads, Each	DF-049-SM	200.00
Wilwood Caliper Brake Pads (Box of 4)	DF-051	13.00
Caliper Cover Kit For Wilwood Calipers Only, Pair	DF-056	130.00
Single Piston Caliper Set With Pads, Pair	DF-009	125.00



DF-049-SM



DF-049-B



DF-049-R



DF-009

TANDEM MASTERCYLINDER

WILWOOD™ Tandem Master Cylinders have ports on both sides for easy brake line plumbing, with 7/8" and 1-1/8" bore size. Available in both plain or polished finish.

Description	Part#	Price
Plain 7/8" Bore Tandem Master Cylinder	DB-132	240.00
Polished 7/8" Bore Tandem Master Cylinder	DB-132-P	288.00
Plain 1" Bore Tandem Master Cylinder	DB-130	240.00
Polished 1" Bore Tandem Master Cylinder	DB-130-P	288.00
Plain 1-1/8" Bore Tandem Master Cylinder	DB-131	240.00
Polished 1-1/8" Bore Tandem Master Cylinder	DB-131-P	288.00



DB-132

WHEEL FIT™ PROFESSIONAL 45 KIT

The Wheel Fit™ Professional 45 will fit most all 4- and 5- lug vehicles including bolt circles ranging from 4-100mm up to 4-130mm and 5-100mm up to 5-135mm. This kit will extend from 14" – 20" in tire bead diameter. It will also extend from 6.5" – 16" in width.

Description	Part#	Price
Wheel Fit™ Professional 45 Kit	AS-111	548.00



AS-111



BRAKE PARTS



THRU FRAME BRAKE LINE FITTINGS

Thru Frame Brake Line Fittings are available in stainless steel to complete your brake line hook-up. Short fittings are for frame thickness 1-1/8" to 2". Long Fittings are for frame thickness 1-1/2" to 2-3/8". Fittings have 1/8" NPT female thread on inside frame end and -3AN male fitting on outside. Weld-in fittings are plain steel with 1/8" NPT female threads on both ends, 2-1/4" long. Bulkhead fittings also available for single thickness frames with -3AN male fittings on both ends. Other adapter fittings available.



PROPORTIONING VALVE AND CHECK VALVES

An adjustable brake proportioning valve is used to balance front and rear brake pressures, especially in disc/drum combinations. One is also required in disc/disc applications, considering that 60% of the braking force transfers to the front wheels, and most street rods run big and little tires. 10 lb. residual pressure valve is used to maintain pressure in rear drum brake lines. 2 lb. is used in some factory caliper applications, such as 'Vette calipers.

Description	Part#	Price
Proportioning Valve	DR-020	46.00
Adjustable Proportioning Valve	DR-023	108.00
2# Residual Pressure Valve	DR-021	24.00
10# Residual Pressure Valve	DR-022	24.00

STAINLESS STEEL BRAIDED BRAKE LINE KITS

- Made of braided stainless steel (-3 hose size) many times stronger and more abrasion resistant than factory rubber hoses. Uses -3AN fitting on frame side of brake line.
- Adds to the high tech look.
- Includes caliper adapters and seal washers.

Description	Part#	Price
Stainless Steel Brake Line Kit - Mustang II Calipers (16" Long)	MP-030	38.00
Stainless Steel Brake Line Kit - GM Calipers, Metric (14" Long)	DF-020	53.00
Stainless Steel Brake Line Kit - Wilwood Calipers (14" Long)	BX-055	38.00
Stainless Steel Brake Line Kit - Wilwood Calipers (16" Long)	BX-055-1	49.00

ADJUSTABLE PROPORTIONING VALVE

Adjustable proportioning valve regulates rear brake pressure, helping to maintain correct brake bias between front and rear brakes.

Description	Part#	Price
Adjustable Proportioning Valve	DR-023	108.00

Description	Part#	Price
90 Degree Fitting, -3AN to 1/8" NPT	LF-004	18.00
Weld-on Tab, Each	LF-011	3.00
Fitting, -3 An To 3/16 Inverted Flair, Each	LF-012	5.00
Tab Fitting Clip, Each	LF-013	2.00
Banjo Fitting, 10mm to -3", Each	LF-014	18.00
10mm Banjo Fitting Bolt, Each	LF-015-A	3.00
10mm Banjo Fitting Washer, Each	LF-015-W	2.00
Thru Frame Fitting Weld-In Kit 1/8" NPT to 1/8" NPT (2-1/8" Long)	LF-018-1	26.00
Thru Frame Fitting Weld-In Kit 1/8" NPT to 1/8" NPT (2-1/4" Long)	LF-018-2	20.00
Thru Frame Fitting Weld-In Kit 1/8" NPT to 1/8" NPT (2-1/2" Long)	LF-018-3	18.00
Thru Frame Fitting Weld-In Kit 1/8" NPT to 1/8" NPT (3-1/4" Long)	LF-018-4	26.00
Inverted Flare T-Fittings (3/16)	LF-020	6.00
Thru Frame Kit, Short -3 AN to 1/8" NPT	LK-001	60.00
Thru Frame Kit, Long -3 AN to 1/8" NPT	LK-002	60.00
Thru Frame Bulkhead Kit, -3 AN to -3AN"	LK-005	67.00
Weld-On Tab Fitting Kit, -3AN To 3/16 Inverted Flair Fittings With Tabs & Clips	LK-007	18.00
Banjo Bolt Kit - Bolts & Washers (10mm)	LK-008	16.00
Banjo Fittings, 10MM to -3AN	LK-009	22.00
Banjo Bolt Kit, 7/16-20 to -3AN	LK-010	12.00
Banjo Fittings, 7/16 to -3AN	LK-011	24.00
Adapters, -4 Male to 45 Swivel	LK-012	27.00
Adapters, -3AN to 1/8" NPT Male	LK-013	8.00
Adapters, -4AN to 1/8" NPT Male	LK-014	8.00

MOTOR MOUNTS, STABILIZER BARS & MUSTANG PARTS

Stabilizer bars are used to control body roll. **HEIDTS®** has an assortment of front and rear bars for your particular application. Made of heat treated steel, these bars will help make your car more stable.

STABILIZER BARS

Description	Part#	Price
Front SWAY BARS		
Camaro Pro-G Subframe Only		
67-81 Camaro/68-72 Nova (1" Diameter)	SB-110	270.00
67-81 Camaro/Firebird/68-72 Nova (1-1/4" Diameter)	SB-111	335.00
67-81 Camaro/Firebird/68-72 Nova (1-1/4" Diameter-Splined)	SB-401	702.00
Camaro Stock Subframe Only		
67-69 Camaro/Firebird/68-72 Nova (1-1/8" Diameter)	SB-069	238.00
70-81 Camaro/Firebird (1-5/16" Diameter)	SB-070	308.00
Chevelle & GM A-Body		
64-72 Chevelle/A-Body	SB-071	227.00
Classic Truck Superide II Only		
53-56 Ford/55-59 Chevy	BS-054-RS	215.00
53-56 Ford/55-59 Chevy (Chrome)	BS-054-C-RS	443.00
Fairlane/Comet Superide II Only		
66-67 Fairlane/66-67 Comet	SB-190	215.00
Mustang/Cougar with HEIDTS® Mustang II Only		
64 1/2-70 Mustang/67-70 Cougar	SB-065	259.00
Mustang Superide II & Nova Superide II Only		
64 1/2-70 Mustang/62-67 Nova	BS-061	205.00
64 1/2-70 Mustang/62-67 Nova (Narrowed)	BS-061-N	205.00
64 1/2-70 Mustang/62-67 Nova (Chrome)	BS-061-C	481.00
64 1/2-70 Mustang/62-67 Nova (Chrome Narrowed)	BS-061-C-N	481.00
Nova Mustang II Subframe Only		
62-67 Nova	SB-060	259.00
Street Rod Openwheel Superide Only		
32 Ford	BS-053	292.00
32 Ford (Chrome)	BS-053-C	470.00
Street Rod Mustang II Only		
35-40 Ford*	SB-001	200.00
37-39 Chevy	SB-003	200.00
40-48 Chevy	SB-004	200.00
49-54 Chevy	SB-005	200.00
47-54 Chevy Pick-Up	SB-054	200.00
41-48 Ford	SB-006	200.00
48-54 Ford Pick-Up, 53-56 Ford F100 & 55-59 Chevy Pick-Up	SB-007	200.00
*SB-001 Fits 33-34 Fords ONLY with a relocation of mounting holes in frame		
Street Rod Superide Only		
32 Ford/33-34 Ford/34-35 Chevy/Model A	BS-055	200.00
32 Ford/33-34 Ford/34-35 Chevy/Model A (Chrome)	BS-055-C	470.00
Street Rod Superide II Only		
35-40 Ford/41-48 Ford/40-48/Chevy/40-46 Chevy Pick-Up/47-54 Chevy Pick-Up		
Plain Sway Bar	BS-056	189.00
Narrowed Sway Bar	BS-056-N	189.00
Chrome Sway Bar	BS-056-C	470.00
Chrome Narrowed Sway Bar	BS-056-C-N	470.00
37-41 Willys Must Use Narrowed Swaybar Only AND Are For Outlaw And IDA Chassis Only		
55 - 57 Chevy Only		
55-57 Chevy (7/8" Diameter With Urethane Bushings)	SB-050-U	200.00
55-57 Chevy (1" Diameter With Urethane Bushings)	SB-051-U	200.00

Stabilizer Bars

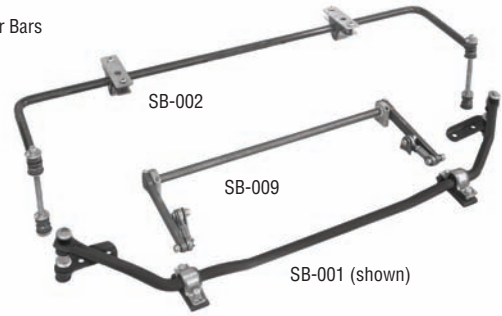

Description	Part#	Price
Rear SWAY BARS		
Camaro 4-Link Only		
67-69 Camaro/Firebird & 68-72 Nova Rear Swaybar (For Use With HEIDTS® 4-Link Kit Only)	SB-009	287.00
70-81 Camaro/Firebird Rear Swaybar (For Use With HEIDTS® 4-Link Kit Only)	SB-170	194.00
Chevelle & GM A-Body		
64-72 Chevelle/GM A-Body Rear Swaybar (For Use With HEIDTS® 4-Link Kit Only)	SB-150	222.00
55 - 57 Chevy (Stock Suspension) Only		
55-57 Chevy (7/8" Diameter With Urethane Bushings)	SB-052	195.00
55 - 57 Chevy Triangular 4-Link Only		
55-57 Chevy (For Use With HEIDTS® 4-Link Kit Only)	SB-180	179.00
55-57 Chevy (Chrome) (For Use With HEIDTS® 4-Link Kit Only)	SB-180-C	443.00
Nova Rear 4-Link		
62-67 Nova (For Use With HEIDTS® 4-Link Kit Only)	SB-130	205.00
Street Rod		
35-40 Ford (Twin Leaf)	SB-002	200.00
Universal Rear	SB-009	287.00

NOTE: These bars can fit numerous applications with modifications to mounts

Now you can add a stabilizer bar to your Mustang II IFS. This simple bracket kit bolts onto control arms. Available in plain, or polished stainless steel.

STABILIZER BAR BRACKET KIT

Description	Part#	Price
Bracket Kit For Stock Lower Control Arms	SB-010	33.00
Bracket Kit For HEIDTS® Tubular Full Lower A-Arms	SB-012	33.00
Polished Stainless Steel Bracket Kit For HEIDTS®		
Tubular Full Lower A-Arms	SB-012-SS	87.00
Left Weld-On Bracket Only	CA-230-L	6.00
Right Weld-On Bracket Only	CA-230-R	6.00



MOTOR MOUNTS

Description	Part#	Price
Universal Motor Mount Kit	MM-110	121.00
Nova Subframe Motor Mounts Only, Pair	MM-120	64.00
64-1/2-67 Mustang Motor Mount Stands, Pair	MM-130	89.00
Superide II Motor Mount Stands For Small Block Ford, Pair	MM-131	89.00
Motor Mounts For Ford Small Block, Pair	MM-135	89.00
Motor Mount Kit Ford	MM-140	92.00

STEERING KITS & COMPONENTS

HEIDTS® steering column hook-up kit is the perfect companion for your independent front end. In fact, it's the strongest, highest quality kit on the market.

WHY IT'S BETTER

- Automotive grade U-joints, w/needle bearing construction, the safest ones available.
- Designed for the automobile environment, they will last the life of your car.
- U-Joints double pinned at each connection for safer, stronger assembly.
- Correct two-piece shaft design allows for ample engine clearance.
- No welding or machining required-column can stay in car during installation.



IDIDIT STEERING COLUMNS

Description	Price
Mustang Tilt Floor Shift Collapsible	
68-69 Mustang - Paintable Steel	CALL
68-69 Mustang - Black Powder Coated	CALL
68-69 Mustang - Chrome	CALL
Nova Tilt Floor Shift	
62-66 Nova - Paintable Steel	CALL
67 Nova - Paintable Steel	CALL
62-66 Nova - Black Powder Coated	CALL
67 Nova - Black Powder Coated	CALL
62-66 Nova - Chrome	CALL
67 Nova - Chrome	CALL
Nova Tilt Floor Shift With Ignition	
69-73 Nova - Paintable Steel	CALL
69-73 Nova - Chrome	CALL
69-73 Nova - Black Powder Coated	CALL
Camaro Tilt Floor Shift	
67-68 Camaro - Paintable Steel	CALL
67-68 Camaro - Black Powder Coated	CALL
67-68 Camaro - Chrome	CALL
Camaro Tilt Floor Shift With Ignition	
69 Camaro - Paintable Steel	CALL
69 Camaro - Black Powder Coated	CALL
69 Camaro - Chrome	CALL
Chevy Tilt Floor Shift	
55-56 Chevy - Paintable Steel	CALL
57 Chevy - Paintable Steel	CALL
55-56 Chevy - Black Powder Coated	CALL
57 Chevy - Black Powder Coated	CALL
55-56 Chevy - Chrome	CALL
57 Chevy - Chrome	CALL
Chevy Truck Tilt Floor Shift	
47-54 Chevy Truck - Paintable Steel	CALL
47-54 Chevy Truck - Black Powder Coated	CALL
47-54 Chevy Truck - Chrome	CALL
Ford Truck Tilt Floor Shift	
53-56 Ford Truck - Paintable Steel	CALL
53-56 Ford Truck - Black Powder Coated	CALL
53-56 Ford Truck-Chrome	CALL
32" Universal Tilt Floor Shift Steel	CALL
Black Powder Coated	CALL
Chrome	CALL

COMPLETE RACK & PINION KIT INCLUDES:

- Splined adapter for the rack end. Specify manual or power steering.
- Two lengths of high quality shafting.
- Two needle bearing automotive type universal joints.
- Machined adapter for steering column (1" column standard. Splined adapter available for other sizes).
- Roll pins supplied in correct lengths. Two pins per connection provided for extra safety.
- Step-by-step instructions.

INDIVIDUAL COMPONENTS

Description	Part#	Price
Bearings		
3/4" Rod End Bearing	SC-020	39.00
U-Joints		
3/4" DD to 3/4" 36 Spline	SC-040	103.00
3/4" DD to 3/4" V Notch	SC-050	92.00
3/4" DD to Manual Rack	SC-060	92.00
3/4" DD to 1" DD	SC-070	97.00
3/4" to 3/4"	SC-210	71.00
3/4" to 1" 48 Spline	SC-211	92.00
1" DD to 3/4"	SC-212	92.00
3/4" DD to 3/4" Bore	SC-213	92.00
17mm DD to 3/4"	SC-217	92.00
3/4" to 5/8" 38 (Vega) Spline	SC-310	81.00
3/4" to 9/16" 26 Mustang Manual Spline	SC-410	81.00
3/4" to 3/4" 36 Mustang Power Spline	SC-510	76.00
3/4" DD to 17mm DD 48 Spline	SC-306	103.00
3/4" DD to 1" 48 Spline	SC-980	114.00
3/4" to 3/4" 30 Spline	SC-610	84.00
3/4" to 13/16" 36 Spline	SC-710	81.00
3/4" 36 Spline to 3/4" 36 Spline	SC-810	81.00
3/4" to 3/4" V Notch	SC-950	76.00
3/4" 36 Spline to 3/4" V Notch	SC-960	97.00
3/4" DD to 3/4" DD	SC-970	97.00
Adapters		
1" Spline to 3/4" Smooth	SC-101	50.00
1" DD to 3/4" DD	SC-102	53.00
9/16" 26 to 3/4" Manual Rack	SC-201	23.00
3/4" 36 to 3/4" Power Rack	SC-202	23.00
3/4" to 3/4"	SC-206	22.00
3/4" to 13/16" 36 Spline	SC-207	50.00
3/4" to 5/8" 38 (Vega) Spline	SC-208	22.00
3/4" to 3/4" DD	SC-214	30.00
3/4" to 17mm DD	SC-215	26.00
3/4" to 1" DD	SC-216	50.00
67 Nova (Splined Adapter)	SC-218	76.00
Shafts		
6" Short 3/4" Smooth Shaft (Mustang/Pinto)	SC-203	8.00
6" Short 3/4" DD Shaft	SC-203-DD	8.00
32" Long 3/4" Smooth Shaft (Mustang/Pinto)	SC-204	16.00
32" Long 3/4" DD Shaft	SC-204-DD	30.00
16" Shaft 3/4" DD	SC-209-DD	20.00
24" Long Shaft (Vega)	SC-303	6.00

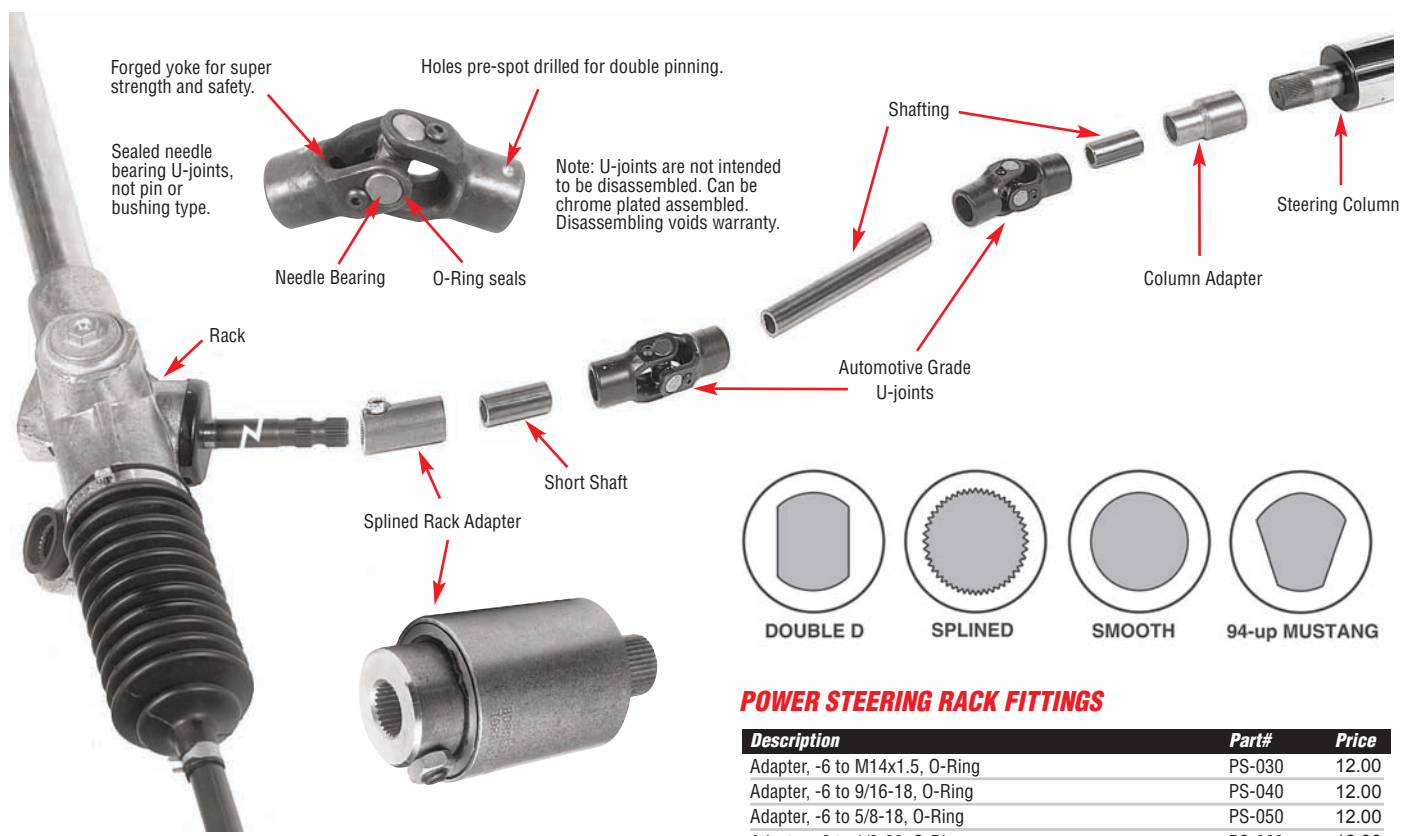

POWER STEERING RACK FITTINGS

Description	Part#	Price
Adapter, -6 to M14x1.5, O-Ring	PS-030	12.00
Adapter, -6 to 9/16-18, O-Ring	PS-040	12.00
Adapter, -6 to 5/8-18, O-Ring	PS-050	12.00
Adapter, -6 to 1/2-20, O-Ring	PS-060	12.00
Adapter, -6 to M18x1.5, O-Ring	PS-065	12.00

ADJUSTABLE POWER STEERING VALVE

Tune your power steering with our Adjustable Power Steering Valve. It allows you to set, or "tune", the "feel" of your power steering with just the turn of a knob. The high pressure steering fluid goes thru the lower high pressure passage to the rack and back thru the upper low pressure line to the reservoir. As the knob is turned counter - clockwise, the needle valve is raised up which allows the high pressure fluid to bleed off into the return line, which reduces pressure to the rack and pinion to tighten the feel of the steering.

Description	Part#	Price
Adjustable Power Steering Valve	PS-101	97.00
Installation/fittings Kit (included in hose kits)	PS-114	71.00

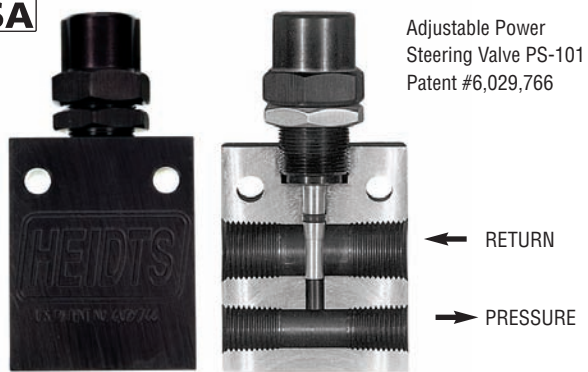

PS-101

POWER STEERING HOSE KITS

Description	Part#	Price
GM Integral Reservoir Pumps for use without valve	PS-110	135.00
GM Remote Reservoir Pump for use without valve	PS-111	173.00
GM Integral Reservoir Pumps for use with valve	PS-112	206.00
GM Remote Reservoir Pumps for use with valve	PS-113	225.00
Installation/fittings Kit (included in hose kits)	PS-114	71.00
Omni Rack with Integral Reservoir w/Valve	PS-116	206.00
Omni Rack with Remote Reservoir w/Valve	PS-117	236.00

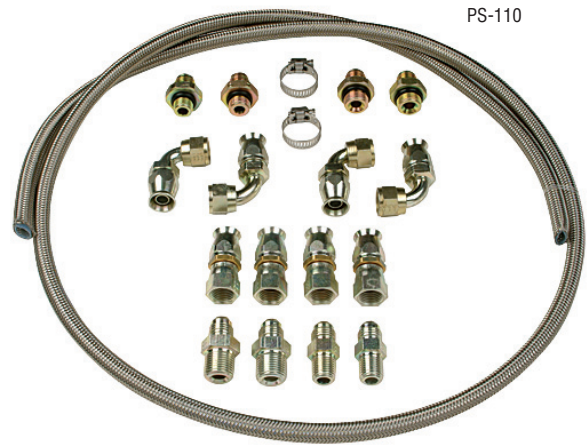

MUSTANG II REPLACEMENT PARTS FOR ORIGINAL FACTORY ARMS



MP-049 **Complete Kit** 200.00
 COMPLETE KIT INCLUDES: MP-011, MP-014, MP-012, MP-015 (2), MP-013, MP-016 (2)

MUSTANG II REPLACEMENT PARTS - INDIVIDUAL COMPONENTS



MP-011
Strut Rod Bushing Kit 35.00



MP-012-P
Urethane Steering Rack Bushings (Pair) 22.00



MP-014
Lower Arm Bushings (Pair) 22.00



MP-013
Upper Arm Bushings (Pair) 37.00



MP-015 **Upper Ball Joint (Ea.)** 29.00



MP-016 **Lower Ball Joint (Ea.)** 29.95



COIL SPRINGS

Description	Part#	Price
Coil Springs, Pr. (275#)	MP-007-275	92.00
Coil Springs, Pr. (300#)	MP-007-300	92.00
Coil Springs, Pr. (325#)	MP-007-325	92.00
Coil Springs, Pr. (350#)	MP-007-350	92.00
Coil Springs, Pr. (375#)	MP-007-375	92.00



UPPER SPRING CUSHIONS

Description	Part#	Price
Upper Spring Cushions, Pr.	MP-006	18.00



SHOCK ABSORBERS

Description	Part#	Price
Plain Shocks, Pr.	MP-005	60.00

HARDWARE KITS



MP-001 **Basic Bolt Kit** 27.00
 (Includes, MP-001-A)



MP-001-A **Upper Arm Kit Only** 19.00



MP-002 **Caliper Bolt Kit** 16.00



Spindle Nut Kit
 HK-006 17.00



Tie Rod Ends Stainless Steel
 MP-017-SS 64.00 Each Plain
 MP-017 22.00 Each



SPRING SPACERS

Cut too much off your Mustang II springs, or have your springs settled just a little too much? HEIDTS® Spring Spacers will get you back in shape. Use these 3/4" thick spacers in place of your upper spring cushions to add just a little ride height back in your ride. Sold in pairs.

Description	Part#	Price
Spring Spacers, Pr.	MP-060	31.00

TOE-IN ALIGNMENT PLATES

Toe alignment Plates allow you to set your toe-in correctly and quickly, by yourself. No more bending under your car and measuring across the tire treads with your buddies! It is all done outside the tires. They come with two plates and two tape measurers, to accurately check your toe-in.

Description	Part#	Price
Toe -In Alignment Plates, Set	TA-003	71.00



4" RACK AND PINION EXTENSION KIT



MP-037-4

For use with PX-104, 104-E, 105, 105-E, CX-308, 308-E, KX-102, 102-E IFS Kits

Description	Part#	Price
Manual	MP-037-4	54.00
Power	MP-039-4	65.00

MP-018



MP-018-C



MP-038-2



REPLACEMENT RACK AND PINIONS

Description	Part#	Price
Mustang II Rack and Pinion, Manual	MP-018	127.00
Mustang II Chrome Manual Rack	MP-018-C	340.00
Power Rack	MP-038-2	229.00
Heids Superide® Rear Steer Manual Rack	BS-004	238.00
Heids Superide® Rear Steer Power Rack	BS-004-PS	524.00

INDEPENDENT FRONT SUSPENSION.

Independent suspension can be very simple and very complicated at the same time. Success in making it simple is learning the rules. **And it has it's own set of rules.** Important, **Rule#1.** Unlearn everything (almost) you know about steering and suspending a car with a solid axle and 4-link suspension. That would be like trying to play football using baseball rules.

The first thing to relearn is the action of the front axle and spindle during suspension travel. There are three things to control in the front wheel: camber, caster and toe angle.

CAMBER AND CASTER

In a solid axle the camber is built into the axle and the caster built into the 4-Link design. Both are constant (they don't change during suspension travel). A solid axle moves basically straight up and down therefore, so does the spindle.

On an IFS System, the upper and lower control arms, as well as the spindle and car chassis, form an uneven parallelogram, as viewed from the front (see fig. 1 & 2). The spindle moves up and down in an arc-or radius-which is determined by the length and placement of the two control arms. Their placement also determines the amount of caster and camber change.

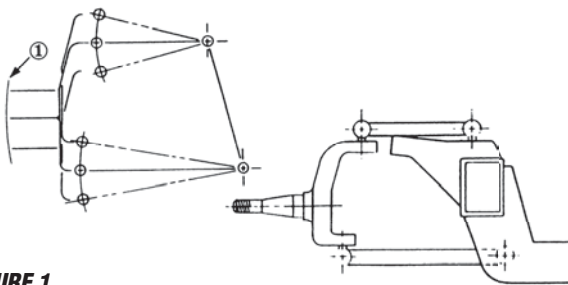

FIGURE 1
This is a correct Mustang II front suspension in a street rod, when the stock Mustang II suspension locations are used. Notice the parallel upper and lower arms. Also notice there is minimal camber change and almost flat radius (1) in the movement of the spindle during suspension travel.

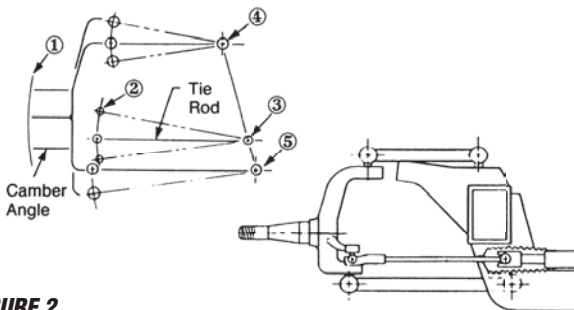

FIGURE 2
Now we have added the stock Mustang II steering rack in the stock Mustang II location using the stock Mustang II tie rod ends. Notice the radius of the rod ends (2) matches the radius of the spindle. Also, more importantly, see that the inner tie rod pivot (3) is IN LINE with the inner pivots (4) & (5) of the upper and lower arms. This is absolutely necessary. Ford Motor Co. did their homework.

Important **Rule #2.** If any of the four pivot points are moved in any direction, for any reasons, the spindle swings in a new, unique arc which is different from the old radius. Usually at the inner pivot of the upper arm on the Mustang suspension is the one to be moved. The control arm is usually shortened and the pivot shaft lowered to clear fenders on some cars (see Fig. #3). As you can see, the spindle will now swing in a new tighter radius. That in itself is not a problem. But, Please read on, as it is about to get real interesting.

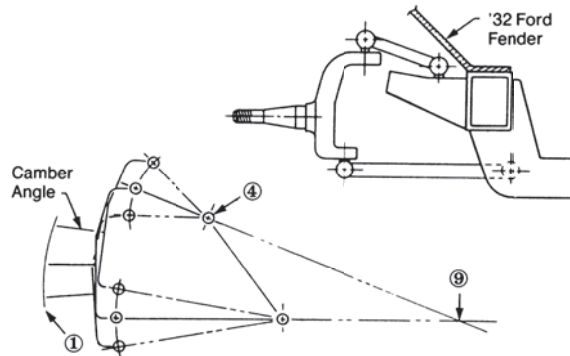

FIGURE 3
This is a typical "modified" Mustang II installation in a '32 Ford type car. The first change is to shorten and drop the upper arm pivot (4) to clear the fender. This causes the much sharper radius (1) of the spindle and resulting increased camber change. Also notice that the two arms now intersect at a theoretical point (9). But this alone is not the bad part. The next step will show you why.

TOE ANGLE

The paragraphs that follow explain why **HEIDTS®** does not make Mustang Kits for certain cars.

As we mentioned, there are three things to control in the front wheel. Camber and caster we've already covered. The third is the toe, or steering angle at which the wheel is pointed, which determines where your car goes.

You can see that this means the spindle must always remain in the direction you have pointed no matter where the spindle is in the suspension travel. This is the job of the "Tie Rod". As you can see, the exact length and location of the inner pivot of the tie rod must be very carefully selected so the outer ends of the rod, which are attached to the spindles, swing in a radius which matches the spindle radius exactly. When designing a brand new suspension system on the drawing board this determination is very easy to make, since the tie rods on the rack are actually designed to match the control arm and spindle radius. But on your conversion, this is where the problems start. So this is the next thing to unlearn.

When mounting a steering box in a solid axle installation, motor mounts, etc. usually dictate the location of the box and the pitman arm is modified to align the drag link with the tie rod. Selecting and installing a rack-and-pinion is nowhere near that simple or forgiving. **When adapting an existing suspension design, such as the Mustang design, it is very important to keep every single mounting location and pivot point, including the rack, in their original designed places.** As you have just seen, the Mustang rack, with a specific tie rod length, was designed by Ford to match the swing radius of the Mustang spindle using stock length Mustang control arms **in the locations which were selected when the Mustang was originally designed.**

If you shorten or lower the inner pivot of the upper arm, the spindle will now swing in a new, different radius which no longer matches the current tie rod radius. If you raise or lower the rack location, or change the tie rod length for any reason by using a longer tie rod end, the tie rod will swing in a new radius which does not match the current swing radius of the spindle (see Fig. #4).

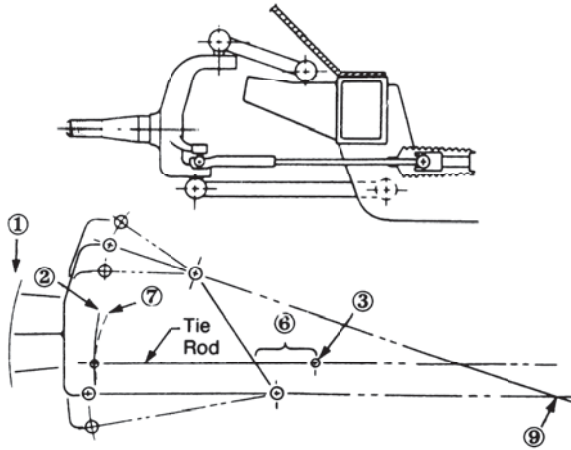

FIGURE 4

...it's all over by now. The other common modification/mistake is to widen the crossmember and use a long tie rod end. Ugh, as you can see, by adding the longer (incorrect) tie rod end, the inner pivot of the tie rod (3) now has been shifted way out of line by the dimension (6). Disaster! The flatter radius of the outer tie rod end (2) no longer matches the sharper spindle steering arm radius (7). This causes the spindle steering arm to follow the incorrect radius (2) and change steering angle, or "steer" as the suspension travels up and down over "bumps": more commonly known as "Bumpsteer". You can also see that the projected line from the tie rod does not intersect the intersection point (9) of the control arms. It should. This is why the only the Mustang II system works correctly is the way Ford designed it, using all stock Mustang II parts, in the stock Mustang II locations.

EXPLAINING BUMPSTEER

The bottom line of all this radius explanation stuff is this: Since the tie rod ends attach to the spindle steering arm, the tie rod controls the steering angle of the front wheels. If your car goes over a "bump" the spindle goes up and down in its swing radius, determined by the upper and lower arms (remember?). If the tie rod swings in a different radius than the spindle during this suspension travel; it will push or pull on the steering arm of the spindle, changing the direction of the front wheel, "steering" the car. And that is how the term and the monster "BUMP-STEER" were created, where 95% of the problems with incorrect suspension design are found. It is from people not really understanding **this most important relationship between the tie rod length (not the overall rack length) and the spindle swing radius.** They feel that if they are able somehow with enough modifications to the parts, to "physically assemble all the parts" that it must be OK. Then they pull down the driveway, over that first curb and low and behold: BUMPSTEER. When you drive a car with BUMPSTEER, the car tends to wander or hop around as you drive down the road over bumps and dips. You have to constantly steer the car to keep it in the lane. Not what you would call an enjoyable ride.

BUILT-IN ANTI-DIVE

Anti dive is another characteristic required in an independent front suspension system. Anti-Dive helps prevent the car from "nose diving" under hard braking conditions, hence the name. It is something which is found in every factory car manufactured, including the Mustang and Pinto, visible in the suspension design in the upper control arm. It is mounted on an angle, with the FRONT pivot higher than the rear, not level (see fig. #5).

FIGURE 5

This is the side view of a correct Mustang IFS kit. Note the angle of the upper control arm, that is higher in front. This angle, through a lot of geometric forces in the spindle when braking, generates a lifting force on the frame at the inner A-arm mounts. This is the same angle as the Pinto, which gives the same amount of anti-dive force as the Pinto. Simply put, factory designs work the way they are supposed to in every respect, so why throw all their engineering and testing out the window?

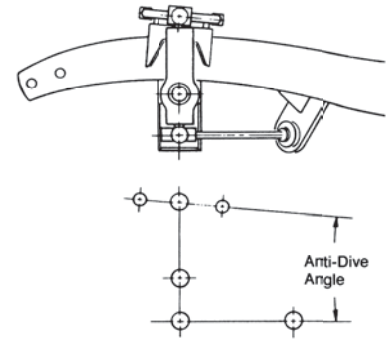

This is the only way to incorporate this important feature, no matter what else you have heard. If you cannot see the angle in the upper arm, then the anti-dive is simply not there. Period.

The actual description of how anti-dive works involves extensive vector force diagrams and is much too lengthy to describe here. Let's just trust the big three auto manufacturers on this one, because they all use it. The Pinto uses a 3° angle for their anti-dive in the upper arm. It may look funny only because you are not used to seeing it on a street rod. Look at your family car. Do things look more normal now?

Don't bother looking for it on somebody else's street rod, especially one with other Mustang kits on it. They don't always know why the upper arms are "crooked" and fix(?) them. But how funny would your car look with the bottom of the grille ground away from bumping the street?

Now for the real point of this whole technical explanation. If you drive a Mustang or Pinto, you know that they don't bumpsteer. If you drive a car using a **HEIDTS®** Mustang conversion kit you will happily find that it doesn't bumpsteer either. Why? Because we don't give you longer tie rod ends which would MISMATCH the tie rod length and it's swing radius with the spindle radius. Because we do not alter the track width which would require longer tie rod ends. Because we don't move the location of the upper control arm pivot or shorten the upper arm (to clear fenders-that is why we limit our applications) which would change the spindle swing radius.

Because HEIDTS® duplicates the design of the Mustang suspension system as Ford Motor Company designed it, you know it will work just as smoothly and effortlessly as it does in the Mustang, which is something no one else can claim. Study the diagrams and you will see for yourself why **HEIDTS®** manufactures the finest Mustang Conversion Kit available. The only one which will truly make your car a pleasure to drive. The **ONLY ONE** that **REALLY WORKS!**

Now that you have examined this technical book, wouldn't you rather purchase one of the most important parts of your car-the front suspension and steering system-from someone who genuinely knows and is able to tell and show you how and why it is supposed to work correctly?

It is important to us that you understand why we build the kits the way we do and have become the leader in Mustang front end conversion kits.

FOR MORE INFORMATION

For more technical information and even more detailed explanation of all the facts presented here, we recommend these books.

CHEVROLET POWER

Fifth edition
Published in 1984 by
General Motors

ADVANCED RACE CAR

SUSPENSION DEVELOPMENT

By Steve Smith
Published By Steve Smith
Autosports Publication

TAP DRILL SIZES

Tap Size	Threads Per In.	Drill Size	Tap Size	Threads Per In.	Drill Size
1/4	20	#7	1/4	28	#3
5/16	18	F	5/16	24	I
3/8	16	5/16	3/8	24	Q
7/16	14	U	7/16	20	25/64
1/2	13	27/64	1/2	20	29/64
9/16	12	31/64	9/16	18	33/64
5/8	11	17/32	5/8	18	37/64
11/16	11	19/32	11/16	16	5/8
3/4	10	21/32	3/4	16	11/16
13/16	10	23/32	7/8	14	13/16
7/8	9	49/64	1	14	15/16
15/16	9	53/64			
1	8	7/8			

TORQUE SPECIFICATIONS

Normal Torque for Tightening Stud Nuts and Bolts
Stud or Bolt Tightening Torque

DIAMETER	IN. LBS	FT. LBS
1/4	55-85	4.5-7
5/16	110-165	9-14
3/8	190-285	16-24
7/16	295-445	25-37
1/2	450-680	38-57
9/16	640-970	53-81
5/8	880-1300	73-110

ENGINE SIZE

Engine size is measured by piston displacement. This is the total volume inches "swept" by all cylinders of the engine.

To determine the cubic inch displacement of an engine.

$$CID = \text{Bore} \times \text{Bore} \times \text{Stroke} \times \text{Number of Cylinders} \times 0.7854$$

STIFFNESS OF COIL SPRING

$$K = \frac{W^4 G}{8ND^3}$$

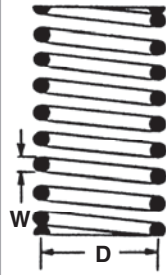

K-Spring rate (lb/in)
W-Diameter of spring wire (in.)
G-12,000,000 (for steel springs)
N-Number of "free" coils + 0.5
D- Diameter of spring coil (in.)
Note how sensitive the stiffness of the spring is to the diameter of the spring wire.

STIFFNESS OF TORSION BAR

$$K = 1,178,000 \frac{D^4}{LA^2}$$

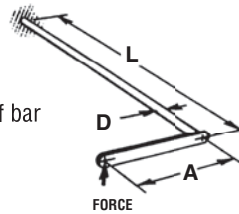

K - Spring rate (lb/in.)
D - Diameter of bar (in.)
L - Length of bar (in.)
A - Length of lever arm (in.)

WHEEL ALIGNMENT

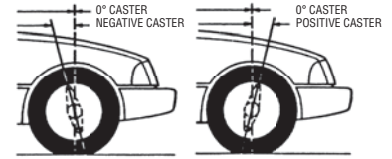

CASTER – the number of degrees of forward or backward tilt of the spindle at the top. Forward tilt of the spindle is negative caster. Backward tilt of the spindle at the top from true vertical is positive caster.

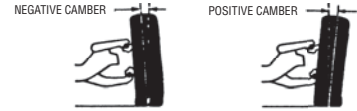

CAMBER – The number of degrees the top of the wheel is tilted inward or outward from true vertical. Inward tilt at the top of the wheel is negative camber. Outward tilt is positive camber.

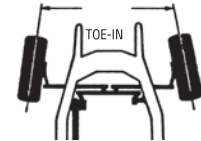

TOE-IN – The distance in inches the leading edge of the front tires are closer than the trailing edge.

SPEED CALCULATION

Many high-performance vehicles are capable of higher speed than their speedometer can register. If the vehicle is equipped with a tachometer, its speed can be estimated with the following formula.

$$MPH = \frac{\text{Overall Tire Diameter} \times \text{Achieved Engine RPM}}{\text{Differential Ratio} \times \text{Achieved Top Gear Ratio} \times 336}$$

HANDY FORMULAS

Circumference of a circle: Multiply the diameter by 3.1416
Area of a circle: Multiply the diameter by itself and then by .7854
Volume of a cylinder: Find the area of the end then multiply by length
Area of the surface of a sphere: Multiply the diameter by itself and then by 3.1416
Volume of sphere: Multiply the diameter by itself and multiply this product by the diameter again. Then multiply this product (diameter cubed) by .5236
Area of a triangle: Multiply the base by the height and divide by 2.

CALCULATING PISTON DISPLACEMENT

The area of head of the piston in square inches, times the number of inches in the stroke, times the number of cylinders, is the engine displacement in cubic inches. The formula is $d^2 \times .7854 \times L \times N = \text{Displacement in Cubic Inches}$. N is the number of cylinders.

“PRO TOURING”

EASY TO INSTALL!



Here is how the **HEIDTS PRO-G® Subframe** installs on one of our shop cars. This bolt-in install takes little time and provides fantastic “Riding on Rails” performance. We completed the car after installing a GM “383” crate, 5sp Tremec transmission, 13” Wilwood disc brakes, NT01 Tires by NITTO and 18” x 9” Foose Rims. Look for this car at Autocross events near you as **HEIDTS®** proves you can drive it to the event - race it - then drive it home!



1. **Unbolt and roll out your old front subframe.**



2. **The new HEIDTS® Front Subframe and only four bolts, completes the installation to the body.**



3. **HEIDTS® 2” Drop Spindle and Upper and Lower Arms mount to HEIDTS® subframe.**



4. **HEIDTS® Front Subframe with Subframe Connectors joins to HEIDTS® Rear 4-Link Kit.**



BOLT A HEIDTS PRO-G® ON YOUR CAMARO/FIREBIRD OR NOVA

HEIDTS® now offers their bolt on front subframe. Featuring their new Pro-G® suspension package for unbelievable cornering and overall handling. Simply unbolt and remove your front sheetmetal, engine/trans, your old subframe, then slide in the new complete **HEIDTS®** Subframe. Reinstall your engine/trans, your sheetmetal and you are set to tear up the streets!

HEIDTS PRO-G®
2” Dropped Spindle

Part of this high performance suspension package. Make your Camaro handle like a 600 HP Go-Kart!

HEIDTS PRO-G®
Suspension

True High Performance purpose designed suspension. Not warmed-over street rod suspension, but true race car designed geometry.

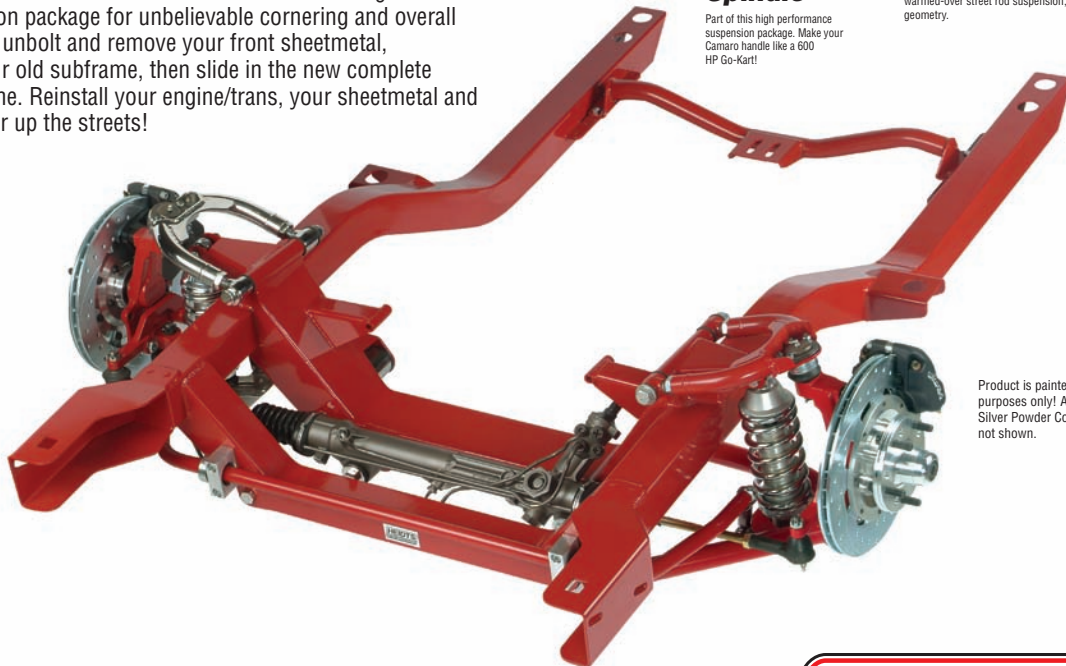

Product is painted for catalog purposes only! All kits ship with Silver Powder Coated Springs - not shown.

Order/Tech: 800-841-8188



“SMOOTH RIDE!”

INSTALLING A HEIDTS® FRONT SUSPENSION IN A ‘35-‘40 CHASSIS

Reprinted By Permission From Buckaroo Communications - Photography: Jeff Tann Words: Jeff Tann

We were talking to fellow street rodder Bob O'Bryant the other day and he told us that he just purchased a '40 coupe that he knew about since the early '60s. The car changed hands a few times, but none of the owners did anything with it. Since the '40 spent most of its time garaged, the body was straight and the chassis was in great condition. The minute the car was on the market, O'Bryant jumped at the chance to buy it.

We asked him what his plans were and he replied, “The usual.” In the old days, that would have been a dropped front axle and a hot Flathead, but today it's quite a different story. “The usual” is actually an independent front suspension with a parallel-leaf spring rear suspension and a small-block Chevy engine backed by a Turbo 350 transmission. That's the econo approach.

O'Bryant said he ordered a **HEIDTS®** front suspension because he was happy with the one under his Model A Ford. We asked him if we could photograph the installation and he was more than happy to let us do a step-by-step story. The front and rear suspension system is exactly what we have on a '40 coupe, so we told him that he would be pleased with his decision.

Ford used the same chassis from 1935 to 1940 on passenger cars and until 1941 on pickup trucks, so the installation is universal for anyone with a car that falls into that category. The install is pretty straightforward if you can follow directions, but it does require welding skill and a few special tools. You will need a MIG welder, 5-inch hand

grinder, large 1/2-inch-chuck drill motor, large hand grinder, tape measure and a variety of normal hand tools. The installation took about a day and a half to finish and it was fairly easy to accomplish.

O'Bryant knew that the suspension would be almost impossible to see under the '40, so he ordered a kit that could be painted or powdercoated. Chromeplating or polished stainless would never be seen. He also ordered the kit with GM-style front brakes because he is familiar with how well they work.

If you have been planning an independent front suspension conversion on your Ford, this story will show you how it's done. The body has been removed from the frame and it was sandblasted, making the conversion clean and easy, but if you have a running car, it could be done by removing the front clip and engine. SRB

The HEIDTS® independent front suspension came with the special crossmember, upper and lower A-arms, a power rack-and-pinion steering unit with ball joints, coilover shocks, spindles, brackets, calipers, rotors and all of the hardware needed to finish the installation. When you consider what you get, the price for this kit is very reasonable.

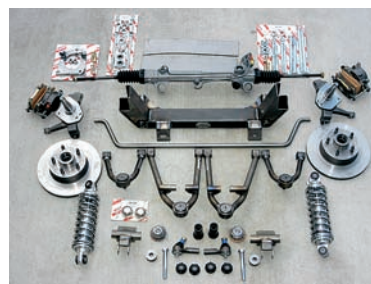

1) A heavy-wall-thickness square tube was tack-welded to the chassis to hold it in place when the stock crossmember is removed.



3) The crossmember was easy to remove when it was moved back to the wider part of the frame. Since these crossmembers are worth money to nostalgia rodders, owner Bob O'Bryant wanted to keep it in good condition. The radiator mounts are still attached to the crossmember and will have to be removed and used after the new front suspension is installed.



5) The HEIDTS® centerline was drawn on top of the frame to make it easy to spot.



2) Using a 3/8-inch drill, the rivets were drilled to remove the shanks.



4) According to the instructions, the centerline for the HEIDTS® suspension will be 1/2 inch back from the straight-axle centerline.



6) O'Bryant decided that it would be better to use a pair of hand clamps to secure the boxing plate before the welding was done. He started by tack-welding the section to the frame at the front and rear.



7) Here's what the framerrail looked like after it was boxed. This strengthens the frame at the point where the crossmember will be installed. Without this, the frame could tear from stress over time.



8) The crossmember was installed and it was a tight fit. A few hammer whacks were necessary to get the centerlines to match up.

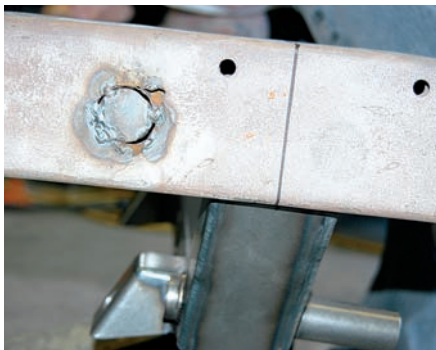

9) Here's the centerline on the frame lined up with the centerline on the crossmember.



10) After all of the measurements were made and the crossmember was located correctly, it was tack-welded to the frame.



11) The upper A-arm mount or tower had to be installed next. It was placed on the frame and extends upward from the lower crossmember.



12) After the towers lined up perfectly, they were tack-welded to the frame. All of the measurements were made again to be certain they were correct. When O'Bryant was satisfied, the towers and crossmember were finish-welded to the frame.



13) The Swaybar block was bolted to the crossmember on the bottom, and when it was in place, the upper bolt hole was drilled and tapped. Doing it this way ensures that the bolt holes will line up perfectly.



14) Bolting the coilover shock to the upper tower started the installation. At this point the bolt was finger-tight just in case it would have to be removed.



15) The lower A-arm was installed using the long bolt supplied in the kit. Washers are supplied to rest against the urethane bushings.



16) The coilover shock was connected to the lower A-arm. This is a long bolt because it is also used to secure the Swaybar connector. The bolt is installed from the front and O'Bryant made sure the Swaybar connector was installed first.



17) The spindle was connected to the lower A-arm. The lower ball joint is long, so spacers are used to make sure the castle nut aligns with the cotter keyhole.



18) Using the other long bolt supplied in the kit, the upper A-arm was installed. This connection also uses the large washers supplied in the kit. The upper bolt is secured with a Nvlok locknut.



19) Now the upper A-arm can be connected to the spindle. HEIDTS® recommended using one of its narrow front suspension kits to keep the tires inside the fenderwell so the tires don't hit on turns.



23) After all the front suspension parts are installed, the bolts can be tightened. The upper A-arm bolts were secured with a pair of 15/16-inch wrenches.



25) Before the rack-and-pinion can be installed, you have to install the bolts with a pair of spacers and washers.



20) The caliper bracket is designed with one bolt on the top traveling upward into the spindle and another bolt on the bottom with a bolt that travels sideways into the spindle.



24) The lower A-arm bolt and Nylok locknut was secured with a pair of 15/16-inch wrenches.



26) The rack-and-pinion unit was reinstalled and then it was tightened with a pair of 15/16-inch wrenches.



21) The rotor was installed on the spindle and then the small spindle bearing was installed. It was also packed with high-heat disc-brake bearing grease.



22) After the rotor was installed, O'Bryant tightened the Allen bolts with a 3/8-inch Allen wrench. At this time, you should make sure that the rotors are centered between the calipers.



27) The chassis is finished and the HEIDTS® suspension looks great and works terrific. The '40 will have positive power steering, should handle like a sports car and will stop quickly with the large brakes. The best part is this kit is priced right.



Reprinted By Permission From
Buckaroo Communications

QUESTIONS & ANSWERS

Q. Are independent suspension kits hard to install?

A. No, not if you purchase the correct type. All of HEIDTS® kits are designed to fit specific model cars exactly. You only need to know the type of car you have, not the frame dimensions.

Q. Do the HEIDTS® Kits work as good as a factory car?

A. Yes, because HEIDTS® does not alter the factory designs. They recognize the fact that the factory spent millions of dollars developing their designs and they are not improved by moving pivot points or changing tie rod ends or other components.

Q. How do the HEIDTS® conversion kits compare to the front subframe swaps?

A. A properly designed suspension conversion kit will ride and handle every bit as good as a subframe swap. The difference in the conversion kit is about one tenth the amount of work. When you cut off your frame rails for a subframe swap, you no longer have a place to mount the fenders or radiator. Besides all that, you have to relocate the motor mounts and often times narrow the subframe, along with the steering linkage. On quality conversion kit, be it a Mustang type or a tubular control arm type, you simply install the crossmember, which should be designed for your particular frame, bolt on the suspension components, then bolt your car back together. The difference is a job that took only a couple of days rather than two or three weeks.

Q. Do you keep your kits in stock or do I need to supply dimensions of my frame so you can build one when I order?

A. The designs of the cars for which we make conversion kits has not changed since those cars were built 40-50 years ago. So, there is no reason to special order a standard kit. All our products are built for stock and are on the shelf ready for shipment, since we already know what your frame looks like, You need only to tell us what type of car you have.

Q. How do you ship your products?

A. All our products except truck freight items, are packaged to ship U.P.S. This is the most economical method. Of course, if you are in a hurry, next day and second day service is available.

HEIDTS® ORDERING, SHIPPING & WARRANTY TERMS.

Payment: U.P.S. orders when paid by Mastercard, Visa, American Express or Discover will be shipped prepaid and the shipping costs will be included on the invoice.

Shipping: We will ship by the most economical carrier. Most orders in the Continental U.S. are shipped U.P.S.

Manufacturer's Rights Retained: HEIDTS® reserves the right to make changes in design or to make additions to or improvements upon any of its products at any time without incurring any obligation whatsoever to install the same or improve upon products previously manufactured.

Claims for Damage or Shortage: Claims for damaged or lost merchandise are to be made to freight carrier. If you receive a damaged package or a package that looks like it has been tampered with, make a written note of this to the freight carrier when you sign for receiving the package. A verbal note to the driver is not sufficient. Carefully open and be sure to save the damaged container as visible proof, this is the first thing they will ask to see! Notify the local office of the freight carrier as soon as possible (within 48 hours). Claims for shortage of merchandise (other than lost items) to be made to us within five days of receipt of order.

Return Merchandise: All sale and final merchandise may be returned only with consent of HEIDTS® Any merchandise accepted for return is subject to a 15% restocking charge. All goods approved for return must be shipped freight prepaid, as the Receiving Department is not authorized to accept collect shipments. Products that have been used or altered in any way cannot be returned. No returns after 30 days.

Guarantee and Liability: Merchandise is guaranteed free from defects in material and workmanship. For one year we will repair or replace, at our option, any product found to be defective subject to our inspection and approval. HEIDTS® will not be liable for personal or property damage caused by use or mis-use of any product we manufacture or sell. User shall determine the suitability of the product for its intended use, and the user shall assume all responsibility and risk in connection therewith.

IMPORTANT LEGAL INFORMATION

This Warranty sets forth our maximum liability for our products. We shall not be liable for special, indirect, consequential, or incidental damages. Your sole and exclusive remedy with respect to any and all losses or damages resulting from any cause whatsoever shall be as specified herein. We make no other warranty or guarantee, either express or implied, including implied warranties of merchantability and fitness for a particular purpose to the original purchaser or to any subsequent user of the product, except as expressly contained herein. In the event state law precludes exclusion or limitation of implied warranties, the duration of any such warranties shall be no longer than, and the time and manner of presenting any claim thereon shall be the same as, that provided in the express warranty stated herein. No distributor, dealer or representative of HEIDTS® has the authority to change, modify or expand this warranty. This warranty extends to the original purchaser (original purchaser means the distributor/purchaser and the initial owner of the vehicle where the product is initially installed) and is not transferable. The original purchaser of this product acknowledges that they have read this warranty, understand it and are bound by its terms and agrees to provide this warranty to the original owner of the vehicle into which the product is installed. Should state or provincial law preclude no transferability, then the warranty period is effective 30 days from the date of initial purchase. ©2014 HEIDTS®

Prices subject to change without notice. All photos Colorized for catalog purposes only!



©2014 HEIDTS® – No part of this catalog may be reproduced without our written permission.

Order/Tech: 800-841-8188

HEIDTS®
SUSPENSION SYSTEMS

OWN THE STREET AND TRACK



- Maximum performance through race winning engineering
- Superior quality using WELD's cold forged alloy technology
- Engineered for high performance modern muscle & pro-touring
- Precise fits from 15 to 20" diameter and up to 16" wide

WELD[®]

RACING



weldracing.com

800.788.9353



View HEIDTS 1968 CAMARO
Equipped with Heidts ProG IFS
and High Horse Power IRS!



**HEIDTS TOTAL
SOLUTIONS**



A TRUE FIT

HEIDTS HEADERS

**DESIGNED TO FIT PERFECTLY WITH
HEIDTS FRONT SUSPENSIONS!**

- 1 7/8 STAINLESS STEEL COMPUTER BENT
- 3/8 THICK LASER CUT FLANGES TIG WELDED TO TUBES
- O2 SENSOR BUNGS INSTALLED
- KITS INCLUDE: GASKETS, HARDWARE AND INSTRUCTIONS
- ALL FLANGES MACHINED AFTER WELDING
- STAINLESS STEEL CONSTRUCTION
- 3 INCH STRAIGHT COLLECTOR TO ACCOMMODATE SEVERAL EXHAUST OPTIONS

CALL FOR YOUR APPLICATION



Order/Tech: 800-841-8188





800 NORTH OAKWOOD
 LAKE ZURICH • ILLINOIS 60047
 TOLL FREE: 1-800-841-8188
 PHONE: 1-847-487-0150
 FAX: 1-847-487-0156
 WWW.HEIDTS.COM



HEIDTS® COMPLETE LINE OF SUSPENSION SYSTEMS FOR YOUR MUSCLE CAR OR STREET ROD

Brake Calipers	Disc Brakes	Motor Mounts	Rear Leaf Spring Kits	Suspension Components
Brake Line Fittings	Disc Brake Conversion Kits	Panhard Bars	Replacement/Rebuild Parts	Suspension Packages
Brake Lines	Disc Brake Parts	Power Boosters	Spring Spacers	Toe Plates
Brake Pedals	Dropped Spindles	Power Steering Hose Kits	Stabilizer Bars	Tubular Strut Rods
Chassis Brace Links	Fender Panels	Power Steering Proportioning Valve	Steering Columns	Universal Brake Pedal Assembly
Chassis Stiffeners	Hardware	Pro-G Subframe	Steering Components	Vette/Wilwood Conversion Kits
Coil-Over Shocks	Independent Front Suspension Kits	Rack Lube	Steering Kits	Vibration Dampeners
Column Hook-Up Kits	Independent Rear Suspension Kits	Rear 4-Link Kits	Subframe Connectors	
Control Arms			Subframes	
Crossmembers				

HEIDTS® superior Sales and Technical Support Team brings years of hands-on automotive and real world Muscle Car & Street Rod experience.



1973 Chevy Camaro
 Randy Johnson
 D&S Customs

1-800-841-8188 • HEIDTS.COM